



University of
Lethbridge



Design and Construction Standards

V1.3 – May 2023

Buildings must grow out of the ground, clustered with other buildings or trees, but never sit blatantly on top of the ground. Forms must be simple and geometrically concise, as elaborate forms and fussy detail show weakness...Just as the prairie landscape has been reduced to essentials, so must its building be elemental, of the earth.

-Arthur Erickson

1.0	INTRODUCTION.....	8
1.1	Overview	8
1.2	Purpose	8
1.3	Ownership of Standard	9
1.4	Form and Content.....	9
2.0	PROCESS.....	10
2.1	Project Administration and Management	10
2.2	Project Development Process.....	10
2.3	Campus Stakeholders.....	12
2.4	Design Review & Approval.....	12
2.5	Project Documentation and Archiving.....	13
2.6	Commissioning Practices	13
2.7	Drawing Standard	14
2.8	Room Numbering.....	14
2.9	[Reserved].....	15
3.0	UNIVERSITY CAMPUS MASTER PLAN	15
3.1	Overview	15
3.2	Framework.....	16
3.3	Implementation	16
3.4	Key Illustrations of Architectural Elements	18
4.0	DESIGN CONSIDERATIONS	20
4.1	General Design Considerations.....	20
4.2	Climatology (Wind, Sun Exposure, Winter)	21
4.3	Archaeological Setting	21
4.4	Campus Ecology and Landscapes.....	22
4.5	Architectural Design Considerations	23
4.6	Signature Buildings	25
4.7	Building Life Expectancy	26
4.8	Sustainable Design	26
4.9	Legacy Materials & Finishes.....	28
4.10	Public Art.....	28
4.11	Accessibility/Barrier Free Design	29
4.12	Campus Environmental Signage System.....	31

4.13	Environmental Health/Indoor Air Quality.....	32
4.14	Hazardous Materials	32
4.15	[Reserved]	33
5.0	TECHNICAL PRACTICES	33
5.1	Sitework/Civil	33
5.2	Structure	39
5.3	Building Envelope Systems	43
5.3.6	Fenestration.....	48
5.4	Interiors.....	51
5.5	Conveyance Systems.....	63
5.6	Mechanical/Plumbing Systems.....	67
5.7	Fire Protection	71
5.8	Electrical Systems.....	72
5.9	Information Technology.....	77
5.10	Furnishings and Equipment	77
5.11	Services	78
5.12	Special Collection and Demolition	80
6.0	STANDARDS OF SPACE DESIGN	81
6.1	Introduction	81
6.2	Instructional Spaces.....	81
6.3	Laboratory Spaces.....	81
6.4	Office Spaces.....	82
6.5	Meeting, Seminar and Collaboration Spaces.....	82
6.6	Study Spaces	82
6.7	Public Spaces.....	82
6.8	Washrooms	82
6.9	Kitchen and Lounge Spaces.....	82
6.10	Service and Support Spaces	82
6.11	Loading/Receiving Spaces.....	82
6.12	Library Spaces	83
6.13	Assembly Spaces	83
6.14	Athletic Spaces	83
6.15	Animal Spaces	83

6.16 Residence Spaces	83
SPECIFICATIONS	84
08 00 00 Openings	84
08 06 00 Schedules for Openings.....	84
08 81 00 Glass and Glazing General Requirements	85
09 00 00 Finishes.....	85
09 06 90 Schedules for Painting and Coating	85
10 00 00 Specialties.....	86
10 06 00 Schedules for Specialties.....	86
11 00 00 Equipment.....	88
11 53 10 Laboratory Fume Hoods.....	88
14 00 00 Conveying Equipment	89
14 20 00 Elevators.....	89
22 00 00 Plumbing	90
22 05 00 Common Work Results for Plumbing.....	90
22 05 53 Identification for Plumbing Piping and Equipment.....	91
22 06 00 Schedules for Plumbing.....	92
22 08 00 Commissioning of Plumbing.....	94
22 10 00 Plumbing Piping and Pumps.....	95
22 11 00 Facility Water Distribution	95
22 13 00 Facility Sanitary Sewerage	96
22 14 00 Facility Storm Drainage	96
22 40 00 Plumbing Fixtures.....	96
22 42 00 Commercial Plumbing Fixtures	97
23 00 00 General Requirements	98
23 20 00 HVAC Piping and Pumps.....	99
23 21 00 Hydronic Piping and Pumps	99
23 23 00 Refrigerant Piping	101
23 30 00 HVAC Air Distribution.....	102
23 33 00 Air Duct Accessories.....	103
23 34 00 HVAC Fans	103
23 36 00 Air Terminal Units	104
23 37 00 Air Outlets and Inlets	105

23 40 00	HVAC Air Cleaning Devices.....	105
23 50 00	Central Heating Equipment.....	105
23 52 00	Heating Boilers.....	105
23 63 00	Refrigerant Condensers.....	106
23 64 00	Packaged Water Chillers.....	106
23 65 00	Cooling Towers.....	108
23 80 00	Decentralized HVAC Equipment.....	108
23 82 00	Convection Heating and Cooling Units.....	108
25 00 00	Integrated Automation.....	109
25 05 00	Common Work Results for Integrated Automation.....	109
25 30 00	Integrated Automation Instrumentation and Terminal Devices.....	109
25 35 00	Integrated Automation Instrumentation and Terminal Devices for HVAC.....	109
25 90 00	Integrated Automation Control Sequences.....	110
25 94 00	Integrated Automation Control Sequences for Plumbing.....	110
25 95 00	Integrated Automation Control Sequences for HVAC.....	111
26 00 00	Electrical.....	113
26 06 00	Schedules for Electrical.....	113
26 08 00	High Voltage Electrical Distribution (15kv).....	113
26 15 00	Low-Voltage Electrical Distribution (120/208v).....	114
26 20 00	ARC Flash Study and labeling.....	115
26 22 00	Transformers (15Kv to 600 or 208).....	115
26 24 00	Switchboards and Panelboards.....	116
26 29 00	Motor Controllers.....	116
26 30 00	Facility Electrical Power Generating.....	118
26 50 00	Lighting.....	119
26 51 00	Interior Lighting.....	119
26 52 00	Safety Lighting.....	120
26 56 00	Exterior Lighting.....	120
27 00 00	Communications.....	121
27 00 01	General Introduction.....	121
27 05 00	Common Work Results for Communications.....	122
27 08 00	Commissioning of Communications.....	122
27 11 00	Communications Equipment Room Fittings.....	122

27 13 00	Communications Backbone Cabling.....	127
27 15 00	Communications Horizontal Cabling.....	129
27 21 00	Data Communications Network Equipment	133
27 22 00	Data Communications Hardware.....	133
27 31 00	Voice Communications Switching and Routing Equipment.....	134
27 32 00	Voice Communications Terminal Equipment.....	134
28 00 00	Electronic Safety and Security.....	135
28 10 00	Electronic Access Control.....	136
28 13 00	Access Control.....	138
28 15 00	Intrusion Detection	144
28 30 00	Fire Detection and Alarm	144
28 40 00	Life Safety.....	147
28 45 00	Water Detection and Alarm	147
28 46 00	Water Detection and Alarm	147
31 00 00	Earthwork.....	147
31 09 00	Geotechnical Instrumentation and Monitoring of Earthwork.....	147
31 10 00	Site Clearing	147
31 20 00	Earth Moving.....	148
31 30 00	Earthwork Methods	148
31 40 00	Shoring and Underpinning	148
31 50 00	Excavation Support and Protection	148
32 00 00	Exterior Improvements	149
32 05 00	Common Work Results for Exterior Improvements.....	149
32 06 00	Schedules for Exterior Improvements	149
32 10 00	Bases, Ballasts, and Paving.....	150
32 13 00	Rigid Paving.....	150
32 30 00	Site Improvements.....	151
32 80 00	Irrigation.....	151
32 90 00	Planting	151
33 00 00	Utilities	152
33 01 00	Operation and Maintenance of Utilities	152
33 14 00	Water Utility Transmission and Distribution	153
33 50 00	Hydrocarbon Utilities	153

33 70 00	Electrical Utilities.....	153
33 71 00	Electrical Utility Transmission and Distribution	154
33 74 00	Extra High Voltage (EHV) Switchgear and protection devices	155
34 00 00	Transportation	155
34 05 00	Common Work Results for Transportation.....	155
40 00 00	Process Interconnections.....	157
40 01 00	Operation and Maintenance of Process Interconnections	157
40 05 00	Common Work Results for Process Interconnections	157
40 90 00	Primary Control Devices.....	158
40 91 00	Primary Control Valves.....	158
40 92 00	Self-Contained Flow Controllers	158
40 93 00	Linear Actuators and Positioners	158
40 94 00	Self-Contained Pressure Regulators.....	158
40 95 00	Rotary Actuators	158
40 96 00	Saturable Core Reactors.....	158
40 97 00	Variable Frequency Drivers	158

1.0 INTRODUCTION

1.1 Overview

The University of Lethbridge Design and Construction Standards provide direction and assistance to professional design consultants in the disciplines of Architecture and Engineering for buildings. It is also a valuable resource to managers within Facilities and other relevant University stakeholders during the planning, design, and construction phases of capital projects. This document includes considerations for on-going maintenance and operation of the University's physical building assets, infrastructure and campus facilities that can be addressed by means of the design and construction process.

This Standards document emphasizes an acceptable level of performance to take advantage of comprehensive consultative processes, avoid restricting creative thought and innovation and to facilitate the application of expertise from collaborative teams in the design process.

Overall, this document represents a best-value approach of creating the most appropriate high-quality environment for academic scholarship and comprehensive research considering the University's long-term vision of stewardship, community engagement and leadership for responsible facilities development.

1.2 Purpose

The University of Lethbridge Design and Construction Standards serve as a framework for all consultants working on new facilities, renovation projects and ongoing maintenance of infrastructure. The content includes information on the Facilities organization and approval processes, the University Campus Master Plan (UCMP) objectives as well as important development principles and design considerations. This document describes the requirements for typical building and site components as they relate to function, flexibility, accessibility, serviceability, and anticipated facility life expectancy. In addition to general criteria, these Standards define and emphasize many characteristics unique to our campus setting. The comprehensive technical guidelines outline the principles for all primary disciplines including architectural, structural, mechanical, electrical, and landscape architecture.

The Design and Construction Standards are not intended to prescribe or limit what might be the most appropriate solution or innovation in a properly considered design context. The Standards should allow consultant teams unfamiliar with the University Campus to quickly understand our context in relation to guiding principles intended to further advance objectives of the University Campus Master Plan as a cohesive long-term vision for our campus.

Several sub-sections of this work are compiled from established University departmental standards in various disciplines. Ultimately these standards influence the design of facilities in conjunction with professional judgement to ensure they are implemented in consultation with the University to an appropriate extent. The University (through Facilities) and their consultants retain ultimate control and responsibility for the design and construction of all capital expansion and renovation projects.

These Standards are intended to be read in conjunction with current construction codes and other applicable provincial standards in force, including the Alberta Building Code (ABC) and Alberta Fire Code (AFC). In no way are the University of Lethbridge Design and Construction Standards to be construed as a replacement for other Municipal, Provincial or Federal codes, standards or current practices which represent minimum acceptable levels of performance in the day these Standards are published. Where the technical design requirements contained herein differ from applicable codes and standards of the day, the most stringent requirements should apply.

1.3 Ownership of Standard

Campus Development is responsible for the coordination and general maintenance of the Design and Construction Standards document in partnership with on-going consultation with all Facility departments. Any request for clarification concerning this Standard should be made to Campus Development.

This document will be reviewed on a regular basis with adoptions made as necessary through subsequent versions. The Design and Construction Standards document for the University of Lethbridge is available online in the 'Forms & Resources' section of the Campus Development website:

<https://www.ulethbridge.ca/facilities/development/content/resources>

1.4 Form and Content

Discretion should be used in reading the intent of each section or sub-section. These Standards are therefore not intended to be copied verbatim into project specifications as a strict specification but should assist design professionals as to the University's desired outcomes.

Section 1.0 – Introduction

Provides an overview explanation of the purpose and source of the standard including where to direct questions about the information presented in the document.

Section 2.0 - Process

A brief description of the design review process and the University's Commissioning Standard is provided. In addition, a synopsis of the required documentation for a typical project is outlined.

Section 3.0 – University Campus Master Plan

Describes and highlights the role of the University Campus Master Plan as it relates to key directives and broad high-level vision for campus and the way the document informs specific aspects of design and construction decisions for projects on our main campus.

Section 4.0 – Design Considerations

Defines the key principles and design considerations that should be applied to all aspects of a project at the University of Lethbridge.

Section 5.0 – Design and Technical Standards

This section organizes detailed information under the Master Format model, detailing specific requirements of building components and systems. This section contains preferred methods and materials in a format which should prove useful for a design team to understand the University's past methods and materials typically specified and implemented within a project.

This section also represents the preferences of various infrastructure disciplines including architectural, electrical, mechanical, controls, grounds, and information technology services but in no way prevents design teams from proposing current or new uses which might be appropriate or will better meet performance requirements.

At times, "Related Documents" are referenced within a section to make the Design Team aware of important related material. It is intended that the Design Team understand the parameters outlined in this section.

Section 6.0 – Standards of Space Design

This section provides accepted space standards to guide design consultants when designing various University spaces design (forthcoming).

2.0 PROCESS

2.1 Project Administration and Management

Campus Development and the Project Management Office (PMO) are jointly responsible for all campus capital development through major institutional initiatives and minor renovations. At a high level, this partnership advances the University's Capital Plan and University Campus Master Plan and facilities development.

Campus Development leads project feasibility and planning activities to establish the key parameters and objectives of an initiative originating within the broader organization of the University. Additional feasibility and business case planning, especially for significant projects, will also occur with the support of additional expert consultation. Most planning exercises include the development of a functional space program (or outline program) to define space requirements and relationships, staff counts or projections and special requirements that define a project.

The transition of administrative responsibility normally occurs after a period of overlap between Campus Development and the Project Management Office during the design stages of a project. Following this transition, a Project Manager is assigned to take an administrative role implementing the project as the University's lead project representative. The Project Manager will utilize judgement along with all the appropriate planning deliverables to ensure conformance with the vision, scope and objectives of a project. After tender, the Project Manager will lead the University's involvement during the construction phase and manage through to project close-out.

2.2 Project Development Process

After obtaining project endorsement, Campus Development initiates planning and pre-design activities for all construction projects at the University. When planning stages are sufficiently complete, the Project Management Office administers the implementation of the project to ensure it meets the requirements set out in planning stages from early design stages through construction and including final project close out.

2.2.1 *Project Development Process Stages*

Vision Strategize Plan Pre-Design	Design Construct Close-out
Initiation/Inception Planning Phases (Campus Development)	Implementation Phases (PMO)

An overview of the Project Development Process and phase responsibilities are typically as follows:

Phase I - Project Initiation

The goal during the Project Initiation phase is to identify the project's objectives, develop a scope, identify the operational structure of the project by key parameters.

This phase depending on the scope of project may require documentation to outline the principal elements of the project.

Phase II - Feasibility, Planning & Pre-Design

This phase involves extensive data collection and essential information gathering (occasionally with consultant assistance), synthesize collected data, inform, confirm decisions, and continue to build consensus among the many stakeholders who are involved in a project.

The process takes a project through several planning stages to develop the documentation needed to adequately describe the project and identify issues that should be resolved and executed during subsequent

design stages. This process includes the activities of functional programming to identify space and functional requirements related to staffing and operations and provide the design basis for costing and schematic design and development activities during the Implementation phase.

At the conclusion of this phase all stakeholders will have:

- A defined understanding of the scope of the project.
- An assurance the project aligns directly with the needs of the institution.
- Confidence the University has done all it can to optimize the use of valuable resources.
- Confirmed accounting and approval of funding.

Phase III - Implementation

The goals of the project defined in the first two phases are translated into tangible forms configuring spatial relationships, technical building systems and products, program verification efforts and design, and eventually, the actual construction of the project.

This phase of the project is the most time consuming and the most expensive and involves detailed design, tendering and construction activities which are conducted by the project team. Design experts translate the requirements developed in the previous two phases into a formal design and prepare construction contract documents. These contract documents are used to describe the design intention of the project in words and graphics which facilitate the purchasing/tendering, construction management and final occupancy of the building.

The implementation phase for design and construction stages is considered to typically comprise distinct project phases well known to design professionals. In Alberta, the design professions (including The Alberta Association of Architects (AAA), the Association of Professional Engineers and Geoscientists of Alberta (APEGA) and Consulting Engineers of Alberta) support a seven-phase process, comprising:

- Pre-Design
- Schematic Design
- Design Development
- Construction Documents
- Tender
- Construction
- Post-Construction/Occupancy/Close-out

While activities in each phase can vary depending on the size and scope of the project, all projects require thoughtful consideration of project requirements and relevant design criteria, identification of constraints and development of solutions to specific questions or problems through the design phases.

At the University's discretion, projects may be delivered through alternate procurement formats such as Construction Management (CM), Integrated Project Delivery (IDP), Partnering or Bridging methods and other forms of traditional project delivery deemed to be in the best interest of the project.

2.2.2 General Maintenance Considerations

Every element of every building must be maintained by a limited staff, using a variety of equipment. Upkeep of the building exterior is as essential as the interior environment and deferral of maintenance for any length of time can become problematic, costly, and even unsafe. Use intensity, weather and climatic conditions will affect the capacity of staff to perform these essential maintenance duties.

The following are examples of issues that must be addressed during the design process:

- How will certain design elements be maintained?
- Will the maintenance staff be able to access all areas of the building exterior for cleaning, upkeep, and repairs using appropriate means of equipment?
- Will overhangs, buttresses, recesses or other design elements create maintenance impediments?
- Will proximity to another building create overwhelming challenges to proper maintenance of either building?
- Will unfamiliar material choices demand extraordinary efforts from the staff in product training, difficult to source cleaning supplies and new repair/maintenance equipment?
- Will selected finishes resist the rigors of academic use, such as dirt, scratches, fingerprints, or other blemishes?
- Will stairways or high spaces create obstacles for maintenance?
- How will light bulbs be changed in all locations?
- If mechanical ducts and pipes are left exposed, will cleaning the dust off them be problematic?
- Will landscaping components interfere with maintenance?

2.3 Campus Stakeholders

A Project Manager is responsible for administering the project and managing the Consultant Team with members of university leadership, faculty representatives and stakeholders. Depending on the nature of the project and the expertise required, typical stakeholders within the University may include:

- a. Senior Administration
- b. Technical Advisory Committee (Project specific appointment within the University)
- c. Stakeholder User Groups (representatives from faculty departments or administrative/ancillary units and/or student representatives as applicable.)
- d. Facilities Representation as required from:
 - e. Campus Development
 - a. Project Management Office
 - b. Building Maintenance
 - c. Grounds
 - d. Utilities (Electrical & Mechanical/Controls)
 - e. Campus Safety
 - a. Caretaking Services
 - b. Information Technology Services
 - c. Materials Management.
 - d. A University Commissioning Agent(s)

2.4 Design Review & Approval

Best design practice requires that formal reports, documenting progress at each phase, be submitted to the University, including Schematic Design, Design Development and other stages of review during drawing and specification production. These reports will allow the University to evaluate the effectiveness and acceptability of a proposed design as it relates to institutional requirements such as the directives contained in the University Campus Master Plan, budget or other design objectives. Review of the proposed design and resulting construction documents for all projects at the University is typically under the direction of the assigned Project Manager.

2.5 Project Documentation and Archiving

All design work must comply with current provincial and federal codes in effect, governing the jurisdiction of work. Drawings should adequately communicate the design intent to contractors and should encompass the full scope necessary to achieve current standards of practice for quality contract documents.

Record drawings shall be produced and submitted for all University projects. At such time, completed drawing sets representing as-built conditions for all disciplines are required in hard copy format as well as a digital CAD (.dwg) submission and Adobe (.pdf) format. Drawings should be represented at their original full-size scale (minimum ISO A0/Arch E plot size). See section 2.7 Drawing standard.

Currently, Facilities has the capability to use AutoCAD as facilities management resource of Building Information Models (BIM).

In conjunction with as-built record drawings, operation and maintenance manuals should be submitted as two hard copies from each discipline: architectural, mechanical, electrical, specifications, and addendums. Copies of record photographs, site surveys, soil reports, and testing results related to the accumulated project documentation must also be submitted.

2.6 Commissioning Practices

Commissioning at the University of Lethbridge is an essential process for ensuring that construction projects are executed as required by their design and functional intents. A properly executed commissioning process can help to achieve the expectation that each project shall perform to the standard developed by the program criteria and operational design intent.

The current University of Lethbridge Commissioning Standard (2008) is available from the University Facilities office through the Project Manager or Director of Operations & Maintenance.

The benefits of commissioning most commonly refer to energy optimization and efficient design features. However, other benefits include improvements to the following: program requirements of the occupant, operation and efficiency, project coordination, operations and maintenance staff training and providing a sustainable, healthy environment.

The commissioning process applies throughout the entire project and a list of commissioning activities associated with each stage of the project is available in the commissioning standard. An established review process is represented with flow charts for review of submitted blueprints, specifications, consultant reports, shop drawings, construction, and deficiency reports, as well as commissioning datasheets.

All new construction projects are monitored by the University of Lethbridge through an internal commissioning agent. The University has created checklists to enhance the review of ongoing construction for the building envelope and related building mechanical, electrical and plumbing systems. The University Building Commissioning Agent will work closely with, and immediately notify, the Project Manager of all observed deficiencies and follow up.

The commissioning process is a broader team effort that requires significant input from several Facility groups and individuals. For the expected responsibilities of each group and their members, refer to the University of Lethbridge Commissioning Standard.

2.7 Drawing Standard

The University drawing standard applies to all building drawings being submitted by external consultants or vendors. As a base requirement in the adoption of files should be able to export AutoCAD compatible drawing files so that base drawing information can be migrated into our space management database FMS Systems and for our facility administration uses and planning analysis.

2.7.1 Drawing Details

The University of Lethbridge follows the United States National CAD Standard - The American Institute of Architects Best Practices methods and Canadian National Standard CAN3 B78.3-M77 – Building Drawings.

Our requirements for preparing and formatting construction documentation align with the most up to date national standards of professional drafting practice in Architecture and Engineering.

All drawing information for new construction should be completed using the metric. Dimensioning methods should be consistent, meticulous and in accordance with accepted standards of professional practice.

Drawings should be carried out to scale at the appropriate magnification to communicate sufficient detail to a contractor and encompass the breadth of information and disciplines required to complete the scope of work.

The drawing list should begin with Architectural, followed by Landscape Architecture, Civil, Structural, Mechanical and Electrical drawings. If a Sustainability Consultant is used, they should be identified on the title sheet along with all other participants contributing to the project team.

A record of submission dates at various project stages should appear on progress drawings for record. Project specification manuals form an essential part of the contract documents paired with drawing submittals and should be accurately complete and coordinated together to reflect the design intent, drawing information and other details.

2.8 Room Numbering

The Project Management Office is responsible for ensuring that a room numbering plan is established during the design development stage of a project. The assigned Project Manager, project architect or prime consultant may propose a room numbering scheme, but guidance and approval must be obtained from Campus Development to coordinate with previous University numbering standards and protocols.

Before drawings are issued for construction, the Project Manager will ensure that the room numbering plan is complete and coordinated with schedules and that reasonable communication is maintained with related departments with vested interest in the subsequent numbering of building monitoring systems, IT servers, electrical panels, etc.

Our typical numbering process is described below:

- During the Design Development stage, the Project Manager will review the room numbering scheme with Campus Development:
- They will ensure that the room numbering sequence is logical so that directional signage can effectively help visitors find their destinations.
- They will ensure consistency with U of L room numbering practices and nomenclature. (E.g. W=Washroom, S=Stairs, H=Hallways, E=Electrical, J=Janitorial, M=Mechanical, T=Telecom, L=Elevator, etc.)

- The Architect/Prime Consultant will provide the sub-consultants and contractor(s) with approved room numbering plans and ensure that all parties coordinate their drawings and specifications in accordance with approved room numbers for the duration of the project.

The Project Manager in coordination with Campus Development will circulate the approved room numbering plans to be used when space management records are created by the following departments:

- Building Maintenance: for use by Locksmith in developing a Keying Plan.
- Utilities: for Building Monitoring System (BMS) programming.
- Electrical: circuit labelling in electrical panels, etc.
- Facilities IT: to create the Building Record in TMA,
- Note: As soon as the location's effective date occurs, the record will be updated as part of the synchronization of TMA with FMSystems.
- Security: for reference in the development of the Security Plan. Security will also circulate to the City of Lethbridge Fire and Police Departments.
- Registrar: Regarding new bookable areas such as instructional spaces and class labs. Remind them to coordinate the new rooms with their SIS database. Include occupant capacities for all bookable rooms.
- Materials Management: Regarding Postal deliveries.
- Conference and Event Services: Should the building include any event type spaces that they will book.
- Information & Technology Services (ITS): regarding network port locations
- Occupant(s) of new space.
- Financial Services-Capital Assets; and
- Sign Shop for directional and room signage alterations.

2.9 [Reserved]

3.0 UNIVERSITY CAMPUS MASTER PLAN

3.1 Overview

The University Campus Master Plan (UCMP) proposes key directives that shape a deliberate high-level land-use strategy that builds upon the University's previous development plans for the University of Lethbridge main campus. The document re-establishes a committed vision with an outlook to 2027 for the institution's future campus that targets intensity in the campus academic core. When followed, the master plan hopes to ensure that the institution's long-term development program is implemented comprehensively, harmonizing both the pragmatics and poetics of what constitutes a campus and further securing the University's long-term viability as a "unique-in-the-world" destination focused on the delivery of quality education, student success and expanding the University's profile as a premier destination institution for higher education and research.

The master plan was developed to be implemented incrementally as the need for specific facilities evolve and as capital funding becomes available. This master plan is intended to serve as a flexible framework for future campus development. The plan identifies meaningful building sites in the campus core, organizes unique interconnected outdoor spaces and profiles an accessible public realm. In this way, campus growth will always reinforce the University's strategic objective for an academic environment that is primed for innovation in a place that fully embraces its spectacular natural setting.

The Design and Construction Standards are intended to be considered as supporting the directives and objectives of the Campus Master Plan. As such, the UCMP serves as a high-level planning framework which expresses a consistent vision for the University of Lethbridge to inform the vocabulary and formalized architectural direction for every project undertaken on campus. It is intended that the Design & Construction Standards will support this

principal framework and not be construed as a manual dictating all the necessary design considerations or requirements for a building or public space to meet UCMP objectives.

3.2 Framework

The University Campus Master Plan (UCMP) framework intends to create a compact, pedestrian oriented and integrated network of buildings and outdoor spaces that strongly correlate with our unique river valley and prairie context. A balance of open landscape spaces connecting with appropriate building form(s) has served as the basis of design since the campus' origin. It is necessary to consistently distinguish the values and goals of the University and campus community as a place of higher learning and achievement through the physical works of architecture that reinforce place-making.

This standards document refers to the Campus Master Plan through its emphasis of existing conditions, planning directions and key urban design and landscape considerations. It is imperative that design professionals and Facilities personnel have a comprehension of the UCMP and understand how the master plan is supported by the Design and Construction Standards presented in this document.

3.3 Implementation

Design considerations presented in the Campus Master Plan document are summarized in the following sub-sections.

3.3.1 Site Development

Planning or design concepts for buildings and public spaces must relate to principles of compactness, desired pedestrian linkages and the integration of enclosed and socially vibrant public spaces and landscapes within reach of campus buildings.

Specific direction has been established as to the permitted location of new building zones (sites) in relation to existing buildings so an integrated campus concept can occur. Extensive geotechnical information related to the University of Lethbridge campus and the surrounding coulee site is available. However, each new project will require further reports and investigations particular to the intended site.

Circulation to and from a building should be considered for both pedestrian and vehicle access. Considerations of boulevards, sidewalks, parking areas and gateway elements should relate to the human scale. Vistas are crucial and deeply rooted in the established framework of the Master Plan. Vistas should be considered from multiple campus viewpoints when establishing building height, form, and orientation on a particular site, including views toward campus from other city or river perspectives. The design should be sensitive to vistas at the pedestrian level as well as from within buildings outward.

Parking areas should be located for the safety of the pedestrian and to minimize the visual impact of broad landscapes of vehicles or empty paving. Coulee landforms should integrate these areas with shallow berms and grading that facilitates storm water management in concert with traffic flows and pedestrian movement. Exterior environmental signage that supports wayfinding should be integrated on site according to campus signage standards and maintain a consistent graphical vocabulary across campus.

3.3.2 *Buildings*

All campus buildings will frame and define the open space components indicated in the Master Plan. The design of new buildings and additions must reinforce the unique sense of place and never overpower the topographical beauty of the site. The design expression of each building plays a role in establishing character on campus.

New campus buildings should be sensitive to the existing signature buildings on campus and their established architectural language (e.g., University Hall).

Simple and dignified palettes for cladding materials are preferred to build a visual cohesion on campus, see Campus Master Plan for material Standards.

Entries should be legible from a distance, with visual prominence of each entry reflecting the hierarchy of the exterior corridor space it serves.

Accessibility is important for the pedestrian network for all users regardless of mobility from the exterior to the interior of all buildings.

Building height must be controlled to achieve a future campus that does not detract from the low, horizontal prairie character of the campus, ultimately avoiding the condition where buildings hover over University Hall when viewed from across the Oldman River.

Intended areas on campus have been assigned for new buildings as they relate to the building type and associated faculty or activities. See development plans within the Master Plan.

3.3.3 *Landscape & Open Space Framework*

Primary pedestrian boulevards shall be tree-lined as a landscaping strategy for linking principal pedestrian pathways.

Tree planting for all primary and secondary streets must be consistent while allowing for a range of seasonal colour, scale, and biodiversity.

The timeline of the academic semester should be considered during plant selection considering the colours and flowering that will be present during fall and spring.

The use of non-native plants is to be avoided to maintain cohesiveness with the natural surrounding coulee landscape.

3.4 Key Illustrations of Architectural Elements

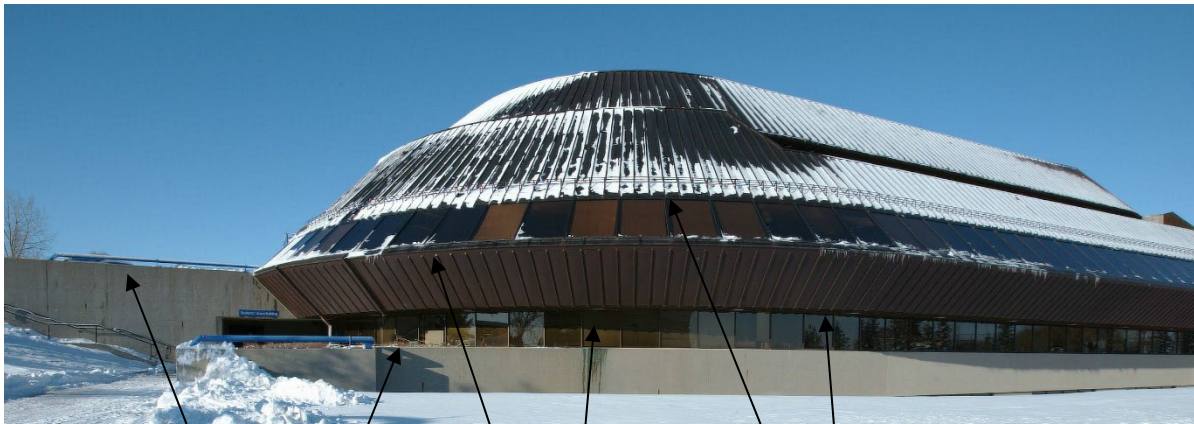

A Pre-cast Conc. **B** Dark Finishes **C** Expansive Glazing



Consistent Architectural Elements include:

- 'Planted' or embedded multi-level siting.
- Simplified or 'reduced' built forms that connect to landscape setting.
- Horizontal emphasis and meeting of prairie/sky horizon line.
- Quality 'earthen' materials and simplified surfaces.
- Indoor / outdoor connection and views.



- A Pre-cast Conc.
- B Dark Finishes
- C Expansive Glazing

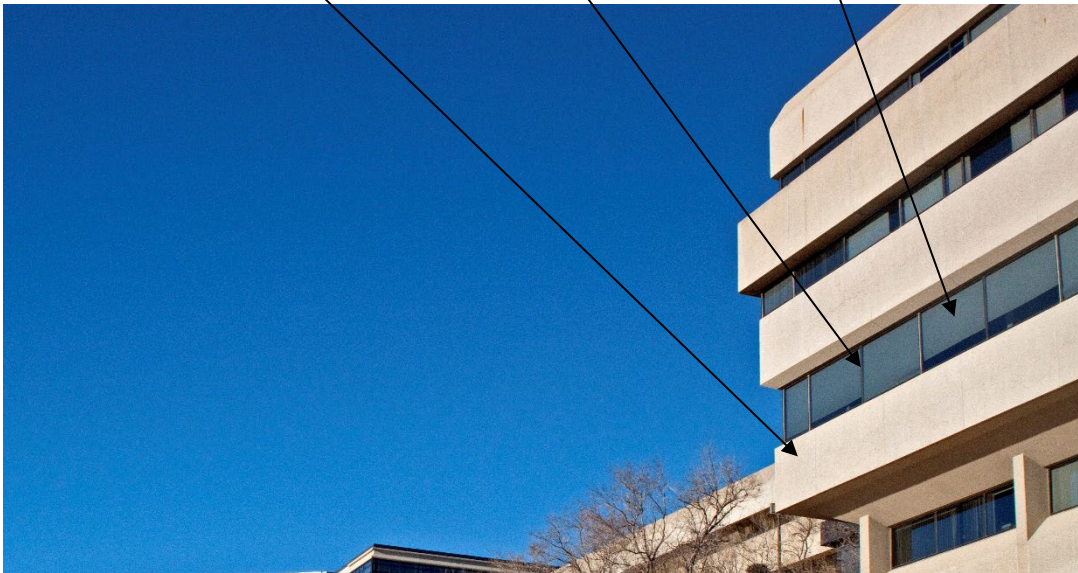

4.0 DESIGN CONSIDERATIONS

4.1 General Design Considerations

General design considerations have been identified for all design and construction projects at the University of Lethbridge. The following considerations must be incorporated into all facilities and developments:

Building/Site Access and Serviceability

- To the fullest extent possible, consider design for universal barrier-free access from campus entry and into and through campus buildings and surrounding public areas.
- Strategies for fire access should not only meet the requirements outlined in the most recent edition of the Alberta Building Code (ABC) but should also proactively and competently address special circumstances related to our unique campus site conditions.
- Provide transparency and accessibility at grade, as well as spaces conducive to social interaction and which enhance a sense of community.

Safety and Security

- Ensure personal protection through design considerations that reduce isolation, hidden corridors and enhance visibility to others. Provide adequate lighting and the ability to access help and escape unforeseen danger.
- Consider appropriate approaches to planning and development that reduce opportunities for crime using Crime Prevention Through Environmental Design (CPTED) principles in the design of buildings and public spaces.
- Limit or reduce University risk to liability through accepted design principles and good practices.

Flexibility and Manageability

- Where possible, provide design features which permit flexibility and reasonably foreseeable adaptive re-use of spaces for future occupancies and/or functions at a minimum cost over time.
- Optimize life cycle costs while ensuring long life for building components and elements that are consistent with the planned design life of the building.
- Provide durable materials and finishes which are easy to access and maintain.
- Provide design features that assist access to systems/equipment for routine maintenance, periodic repairs and replacement.
- Where practical, provide operable building systems or controls where portions of a building can be used efficiently while other areas are unoccupied or closed.

Operations & Maintenance

- To the extent possible, consider long term operation, maintenance and life cycle costs impacted by design decisions, specified materials and equipment.

Geotechnical Instrumentation and Monitoring of Earthwork

- To the extent of good professional practices, sub-surface conditions of building sites are to be understood to inform an advance understanding of potential impacts on building or structural design.
- All design and investigative activities for construction projects shall employ the services of a Geotechnical Engineer who will perform an analysis of the existing building or project site and provide recommendations to University representatives and/or the design team for geotechnical sub-surface conditions and proposed foundation systems.

Related Documents

- University of Lethbridge Slope Stability Review - University Hall (2013), AMEC

4.2 Climatology (Wind, Sun Exposure, Winter)

The City of Lethbridge is located at an elevation of 910 meters above sea level in the southern portion of the province of Alberta, within a climate area classified as semi-arid, which is characterized by relatively low annual precipitation and hot dry winds in both winter and summer seasons.

The following general statements provide general climatic context:

Wind

Of all the climate extremes, wind has the most significant impact on the region and on the elements of buildings on campus. Wind prevails from west-southwest at a 50% frequency. Wind velocity is greatest from these directions creating driving rain conditions up to 200 Pascal. Warm periods during winter occur as a result of westerly winds locally called 'Chinooks'. Cold winter winds are from the north and northeast. Driving snow and heavy drifting also occur due to cold winds and Chinooks. It is important that proper consideration is afforded for wind protection at all exterior entrances as well as elements of detailing and mechanical fastening of building components. Failure to overlook the issue of high dynamic winds can result in a safety hazard for campus goers and threaten the integrity of building components leading to costly repairs and high maintenance costs.

Sun Exposure

As expected in an exposed prairie climate, sun exposure is a serious consideration since the mean monthly and annual hours of bright sunshine are appreciable in southern Alberta (even more so than almost any other place in Canada). Due to this high solar exposure, the often unprotected south-southwest orientation of the site must be treated with special consideration and advantage.

Temperatures

Monthly mean temperatures do not indicate extreme conditions but there can be extreme short-term variations expected in all seasons and should be considered in all aspects of design and construction.

Precipitation

The annual average precipitation is 390 millimeters with maximum rainfall occurring in June at nearly 80 millimeters, clearly indicating regional dry climatic conditions. Maximum recorded 15-minute and 1-day rainfalls are 20 millimeters and 97 millimeters. Droughts in area can be frequent and evaporation is fairly high.

Although recorded in all months, snowfall can occur from September to May. Maximum monthly snowfalls occur in November and February. Snowfalls are frequently followed by relatively rapid melting and runoff due to warm Chinook west winds. Snow drifting is a common occurrence. Site observation suggests that slopes facing south will be covered with deep snow following storm periods, whereas other exposures will have little snow cover.

In addition to the above, design teams should consider climatic information compiled for building design in Division B, Appendix C of the Alberta Building Code, weather station reports and historical data from Environment Canada.

4.3 Archaeological Setting

The coulee landscape is also culturally significant having several early settlement and native archaeological or 'sacred' sites identified on top of specific outcrops or plateau areas. Much of the main campus property has been documented by an Archeological consultant and the information has been compiled into a portfolio of individual reports available in the Facilities resource library.

4.4 Campus Ecology and Landscapes

The University of Lethbridge is situated on the edge of a prairie landscape that gradually slopes down to the Oldman River. These slopes, known as coulees, have been shaped by an ongoing cycle of erosion. The elevation difference between the highest land at the site and the Oldman River is approximately three hundred feet. The site for the university is penetrated by tributary gullies, known as coulees, deepened and widened by a progressive erosion cycle. Native vegetation occurs in the tributary gullies and the prairie land west of the river comprises urban and suburban development formerly cultivated for agriculture.

The prairie landscape is a distillation of various elements that compose the basic perspective of earth abruptly meeting the sky. Building forms caught between this vast horizon appear trivial unless they emerge intrinsically from one or the other or reflect generosity of size at the prairie scale.

An excerpt from the original Development Plan (1969) describes an early approach to our prairie landscape:

Thus, the cluster of farm buildings, widely spaced across sections of land, become isolated accents in the sweeping folds of the prairie: or the groups of elevators rising out of the small town at the railway stop become majestic focal points for vast areas of land and sky. But build a subdivision over the subtle folds of the land and the prairies are destroyed. The grades are too gentle, the contours too soft, to survive the onslaught of an endless scattering of buildings. Without breathing space, vast quantities of it between clusters of buildings, the prairie dies.

The light of the prairies has the clarity of the landforms. The moods are definite, indisputable and range over the base extent of the sky. The light nakedly exposes the landforms and if the forms are weak, extinguishes them. Surfaces become significant, as the reflectors of light, the envelope of form, the source of pattern and color.

A planning report entitled: **Landscape Analysis & Development Guidelines** was created in 1969 to specifically address appropriate means of maintaining sensitivity to our native ecology in the coulee and plateau areas. Although not explicitly practiced today, this landscape guideline is an early design basis for approaching development in consultation with the *Manager of Grounds*.

The University has assembled geotechnical reports discussing the condition and stability of coulee sites and buildings in and around the campus core. The University also monitors building movement in University Hall and the University Centre for the Arts. Design teams are recommended to familiarize themselves with relevant data on hand within the Facilities library collection.

The following general statements provide additional geotechnical context:

Soil Strata

General subsoil conditions consist of lacustrine deposits of layers of sand, silts and clays overlying stiff glacial till soils. Soils are badly weathered and desiccated to a depth of approximately 15 feet. The glacial till underlying the entire site consists of stiff to very stiff, silt-clay containing gravel and coal particles at some depth. Pockets and layers of sand are irregularly located within the glacial till deposit.

Coulee Stability

The natural slopes of erosion gullies on the east side of University Hall range from 2.0m to 3.5m horizontal to 1m vertical. There is surface evidence of creep movement and shallow slump movements along the gullies in most gully areas. Observations on slope stability indicate that a gully slope having a gradient of 2m horizontal to 1m vertical, or flatter, are generally stable.

Erosion

Water erosion is of great concern to our existing buildings and land areas. The existing native vegetation at the bottom of the gullies should be left undisturbed and consideration should be given to the establishment of additional drought-resistant vegetation.

Groundwater

The long-term static groundwater table at the site is located at depth. Temporary perched water tables are encountered across the site because of underground drainage from water storage facilities, urban development, and irrigation to the west and natural movement of runoff draining toward the adjacent river valley.

Mine Locations

Examination of all available data indicates that mined areas do not occur at the main campus property. Abandoned mines are located far to the north and south of the site along the river.

4.5 Architectural Design Considerations

The University should establish consistent architectural excellence in all buildings and public spaces that serve to create a vibrant campus and diverse experience for students, staff and campus visitors. It is natural not only to attempt to incorporate many of the best features of earlier architectural designs for the University of Lethbridge, but to also carry these concepts rigorously further.



Physical Education Building (prior to addition), George Watson, Architect

In our pursuit of architectural excellence, building and landscape design should:

- Draw inspiration from the dramatic coulee setting as a way to enhance campus identity within a differentiated post-secondary landscape.

- Provide architectural solutions for buildings and landscapes that enhance their surroundings, add value to campus and natural environments.
- Overcome the fragmentation of University life common in North America by design that integrates functions usually separated and isolated from one another.
- Make positive contributions to the contextual landscape using simplicity of form as a defining characteristic, and by employing qualities of natural light and volume, without overly complex features and distracting decoration or detail.
- Reveal a committed recognition of architecture's responsibility toward the natural environment and the importance of environmentally sustainable design.
- Address stakeholder needs and functional requirements in combination with the specific regional environment in which campus is located.
- Interior architecture should create a working or living environment that allows occupants to be inspired in our unique setting and enhance their learning or research experiences.
- Excellence in design includes architectural effectiveness through an application of technical knowledge and creativity in building design.

New building and landscape design in the campus core should aim to fit within its context of the campus as a whole. New buildings may vary in terms of style, but by adhering to a set of materials and finishes the campus can maintain a sense of unity and cohesiveness.

To showcase the coulee landscape and mitigate our winter and windy climate, the master plan proposes an interconnected organization of buildings and pedestrian networks. This organization of form also creates a compact campus—facilitating cross pollination between disciplines and encouraging “learning anywhere and everywhere” in a vibrant learning place, integrating academic programs with residential areas for a rich student experience.

The Campus Master Plan reinforces:

- A campus defined by a centre of primary activity within the academic core and boundary,
- Restricting vehicular traffic from the campus centre and academic core except to accommodate service vehicles and delivery access to facilities,
- Highlighting a physical geography that gives shape to building form and other defined public spaces,
- A University Hall that is fully integrated as an important architectural and academic building on Campus,
- Student residences that are integrated into the core campus area,
- Transforming existing buildings to meet the multi-faceted objectives of the master plan,
- Re-connecting outlying campus lands with the academic core using an extensive pedestrian network and strategically located proposed buildings,
- Using open space as a key organizing element,
- Providing frequent moments that re-connect people to the unique coulee setting, and
- Open lands that retain and preserve a sense of prairie/coulee ecology as natural areas within an urban place.

4.6 Signature Buildings



Forefront left: University Hall, Arthur Erickson, Architect
Forefront right: Science Commons, KPMB Stantec, Architect

The University has a number of architecturally significant buildings and important sites and orienting views to and from campus that require attention. Signature precedent buildings that define our campus architecturally include University Hall, the University Centre for the Arts, the Students' Union Building and more recently the Centre for Sport & Wellness which defines the west edge and entry point of campus. Each of these buildings achieves architectural richness and diversity complimentary to the earliest planning and design judgements sympathetic for this unique setting. Buildings such as these can provide a positive and sustained influence on subsequent architectural design thought. These particular buildings are viewed as positive examples because they establish a consistent formal language in response to the context of our coulee site and respond more rigorously to the site than other building outcomes that have occurred since our main campus was established.

As such, the design of new signature buildings should be sympathetic to past architectural gestures while sensitively innovating progressive architectural form and thought to the existing landscape and campus framework. Renovations, in the form of additions to existing buildings in the campus setting should be sensitively crafted and rooted in the physical context of this place and respond to the consistently excellent attributes of our buildings and spaces.

All consultant-led design explorations should be coordinated with Campus Development, including at times owner representatives in order to have appropriate involvement and discussion to determine suitable elements that are to be preserved or enhanced and to provide feedback to design teams.

Open spaces on campus, such as the 'prairie' quad and planned 'coulee' quad in the academic core are to be framed by signature-type buildings which define the academic core as noted in the University Campus Master Plan.

Depending on the intended location of each new building, established objectives will shape the desired outcome for all spaces on campus and affect the design of new signature buildings as they relate to:

- Building mass and scale
- Connection to adjacent buildings
- Roof accessibility
- Communicate or establish a beacon or gateway
- Accommodate pedestrian movement and link to existing pathways
- Avoid disruption or distraction from the coulee landscape
- Incorporate an intended transparency

For more detailed information on guidelines for built form, please refer to the Campus Master Plan.

4.7 Building Life Expectancy

The University is a long term owner/operator of their properties, buildings and infrastructure. Like other large campus institutions, design for building life expectancy should reflect this long-term commitment within the context of their facilities and development plan. Design considerations should adequately address the durability and maintenance of building components within climate extremes that affect Lethbridge and area.

Wherever possible, building components for all noted signature types should be designed for a minimum/optimal life expectancy as follows:

- 100 years for the super/sub-structure and inaccessible components,
- 50 years for building envelope systems (except roof assemblies),
- 25 years for built-up membrane roof assemblies (metal roofing, where permitted, should provide a 50 year life expectancy),
- 25 years for interior components, and design to allow flexible change,
- 30 years for mechanical systems (without major upgrade or replacement),
- 30 years for electrical systems (without major upgrade or replacement).

4.8 Sustainable Design

It is the intention of the University to create a healthy and sustainable environment on campus. Therefore, site and building development must be sustainable in the long term and responsive to the natural environment.

Regardless of any form of green building certification, consideration should be given to innovative design strategies providing improved or renewable forms of energy use, improved water management, employment of appropriately durable materials, reduce site impacts, improve indoor air quality, life cycle costs and efficient means of adapting buildings for future change of use with minimal impact to operations and cost.

4.8.1 Sustainable Design Accreditation

At this time, the University of Lethbridge requires that all new major academic buildings designed and constructed on campus meet the minimum requirements of Leadership in Energy and Environmental Design (LEED) Silver certification. However, on a case-by-case basis, it may not be the University's intention to have a project undergo formal LEED certification by the Canadian Green Building Council (CaGBC). Instead, as a general rule, the sustainable design practices and procedures that compliment good building design shall be maintained for all projects. The University reserves the right to pursue any form of green building certification (LEED being one form of this certification).

The University of Lethbridge requires that the Prime Consultant conduct an energy charrette with Facilities representatives for all projects. The purpose of the charette is to review and refine a preliminary certification checklist with an understanding of the potential energy savings to be pursued by the design team. The University will only pursue certification system points (i.e. LEED) based on merit, feasibility and value.

4.8.2 Energy Use Guidelines

Buildings are the largest consumers of energy and the greatest source of greenhouse gas emissions on campus. The University requires that all designs, regardless of size, adhere to an energy management policy and procedure and that energy conservation methods are considered and reviewed prior to finalizing a design.

All new buildings and major building retrofits or additions must be designed to meet a prescribed energy use target through design approaches noted below.

In the design of new campus buildings, or the significant renovation/addition of existing buildings, the consulting team must have a comprehensive, integrated approach to energy optimization that seeks to:

Reduce heating, cooling and lighting loads through climate-responsive building massing, orientation and envelope design.

- Evaluate opportunities associated with the use of passive/natural energy sources such as economizer cycle-free-cooling, passive solar heating, and natural ventilation.
- Specify HVAC and lighting systems that consider efficient operation at full and part-load conditions.
- Optimize building performance using energy modeling programs early in the design process.
- Demonstrate compliance with performance targets at each project phase (including Schematic Design) prior to advancing to the next project phase.
- Specify sufficient system metering to allow on-going analysis of building performance and effective re-commissioning.
- When applicable, comply with the LEED Canada certification system requirements for Measurement and Verification.
- The proposed design will include all energy consumption and costs within and associated with the building project. Unregulated loads are to be modeled accurately to reflect the actual expected energy consumption of the building.
- The University of Lethbridge will establish an energy performance target as part of the Project Brief.

Strategic building systems and operations to be considered to achieve noted objectives include, but are not limited to:

- Free cooling
- Heat recovery (i.e. heat wheels)
- Variable frequency drives
- Variable flow systems
- High temperature differential systems (hot water and chilled water systems)
- Variable air volume systems
- Demand control ventilation
- Time of day scheduling
- Thermal storage (if feasible)
- Instantaneous hot water heating
- Low water consumption plumbing features
- Displacement ventilation
- Low electrical consumption high lumen output light fixtures
- Occupancy control

Energy management considerations should provide a simple pay back. The maximum pay back of any option will depend on the nature of the equipment and life of materials being considered. All energy considerations should be performed in concert with proper exterior wall assemblies for total building envelope design, coordinated with mechanical systems engineering.

4.8.3 *Sustainability Goals of the Campus Master Plan*

The University of Lethbridge insists that its land resource will be used sustainably to develop smart density that is compact in formal organization through the calculated infill of buildings (avoiding previous tendencies for sprawl) and instead improve walk-ability, social connections and to reserve land for open space and future academic or research needs. Effort should be put into the design of all new buildings with regards to enhancing pedestrian and cyclist access and reducing vehicular traffic and emissions.

4.9 **Legacy Materials & Finishes**

The University campus has developed a rich legacy of architectural finish materials derived from a perception of land-based material palettes. The longevity and durability of all materials and finishes must be scrutinized. Campus buildings are intended to be in place for many years, therefore materials and finishes must maintain their aesthetic appeal over time.

Materials consistent with the vocabulary of campus buildings include:

- Pre-cast Concrete, light sandblast finish.
- In-situ Concrete, varied aggregate, light sandblast finish.
- Wood, Cedar or Douglas Fir.
- Copper and Zinc.
- Weathered Steel.
- Earth Berms/Native Vegetation.

Other permitted materials include:

Prefinished Metal Panels (sympathetic colours).

- Composite Aluminum or Phenolic Laminated Panel Systems.
- Clay Tile Facade Systems.
- Stone, Tyndall 'Tapestry' Limestone.
- 'Architectural' Concrete Block.
- Cement Composite Facade Systems.
- Insulated Rammed Earth.

Prohibited materials include:

- Exterior Insulated Finish Systems (EIFS)
- Stone, Concrete or Brick Masonry slips (50 mm or thinner veneer tile)

If vegetated green roofs are to be used, their performance and maintenance should be evaluated for our semiarid climate. They should also be innovative with respect to where they are located in an attempt to camouflage the visual impacts of visible roof/patio areas and views and educate and promote the public use of green roofs as patio areas. Green roofs must manage storm water appropriately, improve building energy efficiency and maintenance and reduce heat island effects.

4.10 **Public Art**

The University of Lethbridge has an extensive art collection and renowned art program. It has the ability to host an expanded, high-quality public outdoor art collection. An outdoor art collection should support The Campus Master Plan vision—bringing meaning and interest to the campus landscape; acknowledging the University's commitment to artistic trends and movements.

At this time, there is no designated percentage of a project's budget allotted for public art and considerations are made on a project-to-project basis.

Art is a public benefit and should be considered for campus public areas and outdoor spaces to enhance our campus as a cultural destination for the campus community, visitors and local residents.

Approved artwork should be integrated with architectural planning and design so as to create publicly accessible areas—landmarks throughout campus—and contribute to the identity and character of the academic core and precincts.

Public art should provide professional artists with a variety of opportunities to enrich the campus environment through unexpected moments of beauty, amusement, reflection or intrigue. These works of art might serve as way-finding monuments or memorials or represent other creative, innovative and exploratory ideas or expressions for the area.

Key places for outdoor art include:

- Prominent art locations on campus will be reserved for artworks of considerable distinction carrying meaning for the whole campus community (i.e.. Aperture Drive, “Prairie-Quad”, South Coulee)
- Community level artworks will be encouraged to locate within internal, smaller public spaces
- Art is encouraged in locations visible from campus social spaces or main vehicle and pedestrian routes
- A sculpture garden will be encouraged in the future Coulee-Quad as a prominent display area for a number of arts works
- A majority of the outdoor art pieces will be concentrated within a five minute walking distance of the campus core to increase the collection’s impact and accessibility to the campus community
- All outdoor art will be sited in a manner consistent with prominence and significance of the piece and the prominence or character of the campus setting
- All formal collection works will be installed where they can be seen by the broader campus community through the use of accessible pathways or viewing points from which to enjoy the art
- The meaning and origin of outdoor art pieces will be interpreted and available to people using high quality, well-placed information panels and/or plaques.

4.11 Accessibility/Barrier Free Design

The desire for accessibility, both visual and physical access, should be provided at building grade level where highest pedestrian activity occurs. To the utmost extent possible within a prescribed scope of work or boundary, consider design for universal barrier free access starting from entry to the site and between and through campus buildings and public areas.

Standards for accessibility and barrier free design should not only meet the requirements outlined in the Alberta Building Code (ABC) but should aim to achieve the higher standard of the Alberta Barrier Free Standards Guide as well as other national guidelines and standards.

4.11.1 Barrier Free Path of Travel

Barrier-free pathways allow the movement of people by removing or minimizing obstructions and hazards. Temporary hazards are often overlooked, e.g., snow removal often results in snowbanks along sidewalks, which block access. Free-standing or cantilevered staircases, escalators, ramps and intermediate floor levels shall be avoided or have a barrier to prevent access to the overhung area.

Temporary signs or parked vehicles shall not block a path of travel. Wind buffers shall be set back from the sidewalk in such a manner that the walk will still be protected from winds, yet the snow will be deposited next to the walk rather than covering the walk.

4.11.2 *Ground, Floor and Wall Surfaces*

The tactile quality of surfaces shall be designed to support visual information regarding orientation, direction and location. Surface materials in circulation routes shall not impede pedestrian movement, particularly for those in wheelchairs, or distort the perception of people who are visually impaired. Likewise, wall surfaces shall not distort perception or cause physical harm.

Since ground and floor surfaces are an important aspect of access, they should be designed to ensure safe and easy movement. It is important that the freeze/thaw cycle and positive drainage be considered when designing ground surfaces. There should be consistency of materials and colours in recurring situations to provide satisfactory sensory information about the environment.

Where possible, auditory information shall be used in conjunction with visual information. There shall be a balance between too soft/absorbent and too hard/reflective materials and surfaces. Some sound reverberation aids people who are blind by providing a sense of the size of the space and the location of walls or openings, while some sound absorption helps people who are hard of hearing by reducing background noise.

Outdoor floor and walking surfaces shall not have surfaces made of brick or stone, unless they are laid on a firm base and level with adjacent surfaces and embedded in concrete. Gratings, manholes and catch basins shall be located outside of walkways wherever possible or be flush with the adjacent surface. Elongated openings shall be perpendicular to the pedestrian flow.

Carpets that are laid on the floor, stairs or ramp surfaces shall be securely attached. They shall have a tight weave, low pile, and firm underlay. Exposed edges of carpet shall be fastened to the floor surface with trim along the entire exposed edge. The carpet trim shall be beveled with a slope of no greater than 1 in 2. All floor finishes shall be slip resistant, continuous, and stable. The floor surface shall have a coefficient of friction of no less than 0.5 wet or dry.

Nosing on interior/exterior stairs shall be provided with a contrasting material colour to aid people with visual or depth perception impairments and provide traction from slipping. Bright yellow painted warning strips are discouraged and do not meet the above intent. Wall surfaces shall not be extremely rough or uneven. They shall be tactile without causing discomfort or injury and wall fixtures shall be recessed. Wall surfaces shall have a matte finish to prevent glare.

4.11.3 *Illumination and Acoustics*

High levels of illumination consistent throughout a setting improve a person's ability to see. Consistency in the levels of illumination is a primary concern for people with visual impairments, since their ability to adjust from one level to another is often slow. This is particularly important when making the transition from the exterior to the interior. The level of illumination shall be increased to emphasize stairs, entrances, obstacles, information signs and hazardous areas. Lights must be controlled and directed so that they do not create sources of glare. Increased levels of illumination or a greater distribution of fixtures for outdoor lighting is important to people with visual impairments.

Windows shall be designed and located and shielded to prevent excessive solar glare, especially in areas of public circulation.

Minimizing ambient noise and layering of different sounds improves a person's ability to hear. Background noise can be difficult for a hard-of-hearing person. Carpets or sound-absorbing materials shall be used on floors to aid people who are hard of hearing. The placement of public address systems speakers shall not be near crucial areas of communication, such as over an information or service desk.

4.11.4 *Location of Controls, Dispensers and Receptacles*

Often building controls are either too high, too low or too far away to reach. Some controls are too difficult to grasp and turn. Controls shall require only one hand to operate. Emergency controls shall not be placed beyond accessible reach for people who may be seated in wheelchairs. Buildings used by the public shall have controls at a height that can be reached by most everyone without excessive stretching or bending.

Automatic door controls are often too high, too low, or too far away to be accessible. Controls, dispensers and receptacles shall not require the use of two hands, or two simultaneous movements by one hand to operate.

All washroom fixtures shall be installed for safety and ease of access. A single-function towel dispenser (requiring only one hand and only one movement to release the towel) is recommended. Lavatory faucets shall have a lever type action for ease of operation to disabled persons.

4.12 **Campus Environmental Signage System**

The University has a Campus Sign System in place which describes the breadth of exterior and interior wayfinding and information signage and map systems permitted for use. Many of the signage elements are produced by sign personnel within the Building Maintenance department of Facilities. Consistency in signage format, hierarchy and communication is the objective. Proposed modifications or adaptations to the Campus Sign System must be approved by Campus Development. Any modifications must use the same sign materials and fonts as the standard signs and any changes in size of the sign must be appropriate to its destination.

A detailed signage plan should be prepared during the design stage of the project by the Project Manager, who should then review the plan with Campus Development. An estimate of signage cost should be included in project budgets. Consult the sign costing table in the Campus Sign System document for a list of approximate sign costs to be used for budgeting purposes.

Consideration should be given to the fact that buildings are approached and entered from directions other than the through the main front doors. Therefore, secondary signage should clearly identify the name of each building where alternate entrances are regularly used.

The following general statements apply to guide design considerations for way-finding elements:

- Pedestrian, bicycle and vehicular routes should be clearly labelled on campus which helps clarify permitted movement and direction.
- Any newly proposed signage, lighting or mapping strategies should be developed based on the existing strategy. This should include:
 - Strategies to improve road signage, internal street identification signs, an expanded family of vehicular directional signs, and an improved system of parking lot identification and classification.
 - Pedestrian signs should consist of directional signs attached to existing campus sign/lampposts. Coloured bands at the lamppost base should identify the major campus walks, coulee trail systems, and river points. Directional “finger” signs at key intersections will help visitors quickly find their way with minimal visual impact.
 - A comprehensive and consistent identification of campus buildings should help visitors and new campus residents find a destination. Improving the visibility of existing inscriptions with guidelines for contrast and fill colours will also improve their legibility.

Although it is not included in our Campus Sign System manual, the introduction of new information kiosks at key points of arrival could be considered. Wayfinding is media, website, or handheld device. Temporary portable signage directed toward vehicles on University Drive and campus access roads are to be avoided whenever

possible with preference given to communicating this information by means of the modestly scaled existing digital pylon signs near campus road entrances.

4.13 Environmental Health/Indoor Air Quality

Facilities must be designed and constructed with an appreciation of the importance of providing high-quality, interior environments for all users. During the facility design and development process, projects must have a comprehensive, integrated perspective that seeks to:

- Facilitate Indoor Environmental Quality (IEQ) through good design, construction, and operating and maintenance practices.
- Value the importance of views and daylighting for work places and public areas
- Provide thermal comfort with a maximum degree of personal control over comfort parameters.
- Supply adequate levels of ventilation and conditioned outside air to ensure Indoor Air Quality (IAQ).
- Control outside air quantities provided to spaces with highly variable occupancies using CO₂ monitoring or occupancy-based demand-controlled ventilation.
- Prevent airborne bacteria, mold, and other fungi through heating, ventilating, air conditioning (HVAC) system designs that are effective at controlling indoor humidity and building envelope design that prevents the intrusion of moisture.
- Avoid the use of materials high in pollutants, such as volatile organic compounds (VOCs) or toxins.
- Assure acoustic privacy and comfort using sound absorbing material and equipment isolation.
- Control disturbing odors through contaminant isolation.
- Create a high-performance luminous environment through the careful integration of natural and artificial light sources.
- Construction activities shall seek to prevent indoor air quality problems resulting from the construction process to help sustain the comfort and well-being of building occupants.
- Enact a building flush-out after construction ends and before occupancy.
- Project contract documents shall include a requirement for baseline indoor air quality testing. A representative sample of spaces, as determined on a project-by-project basis, shall be tested for formaldehyde, PM₁₀, TVOC and carbon monoxide levels before and after construction ends.
- All University of Lethbridge buildings are designated non-smoking facilities. Any exterior smoking spaces provided shall be adequately distant from the building to not contribute to smoke infiltration into the building.

4.14 Hazardous Materials

Installation of any material or equipment which contains asbestos, lead coating or other hazardous material is not permitted. At project start-up for projects involving demolition of existing buildings or parts of buildings, review the potential for hazardous materials being present with the Project Manager and Safety Officer, as necessary (i.e., chemicals and gases stored in laboratories, etc.). If hazardous materials are suspected and/or found during any site investigation of as-built conditions, this must be reported immediately to the Project Manager. Design consideration must be given to the potential for hazardous conditions, such as strong magnetic fields from NMRs and MRIs, chemical, and venting of gases.

Hazardous materials which may be present include:

- asbestos contaminated materials
- lead based paints
- laboratory chemicals
- radioactive materials
- biohazards
- refrigerants
- underground storage tanks
- oil-water separators

- PCB's and/or mercury
- devices that contain oils (transformers, hydraulics, etc.)

4.15 [Reserved]

5.0 TECHNICAL PRACTICES

5.1 Sitework/Civil

Intent

To the extent of good professional practices, sub-surface conditions of building sites are to be understood to inform an advance understanding of potential impacts on building or structural design.

5.1.1 *Geotechnical Considerations*

Practices

All design and investigative activities for construction projects shall employ the services of a Geotechnical Engineer who will perform an analysis of the existing building or project site and provide recommendations to University representatives and/or the design team for geotechnical sub-surface conditions and proposed foundation systems.

Related Documents

University of Lethbridge Slope Stability Review - University Hall (2013), AMEC

5.1.2 *Excavations*

Practices

The main campus has unique soil conditions and an elevated water table that become issues for both shallow and deeply excavated buildings (such as University Hall, the Centre for Sport and Wellness, and others).

Related Documents

University of Lethbridge Slope Stability Review - University Hall (2013), AMEC

5.1.3 *Landscape Works (See also Section 3.3.3)*

Practices

Landscape and building design should be conceived and designed as a single composition. All campus areas will include signature plant species as a means of unifying the campus landscape. Tree planting for all primary and secondary streets must be consistent. Be aware that when the soil is compacted in winter it tends to slump away from sidewalks and curbs as the ground thaws in the spring. Therefore, a soil compaction of 95-97% is required around sidewalks and curbs.

Sidewalks must have as a minimum a 1.5m (5 ft.) width. This width is separate from rolled curbs, sign posts, or fire hydrants. These intrusions hinder the use of snow clearing equipment and pedestrian traffic flow, particularly for the less-able. Avoid the use of 90 degree or acute angles. See figure 5.1.3-A below.

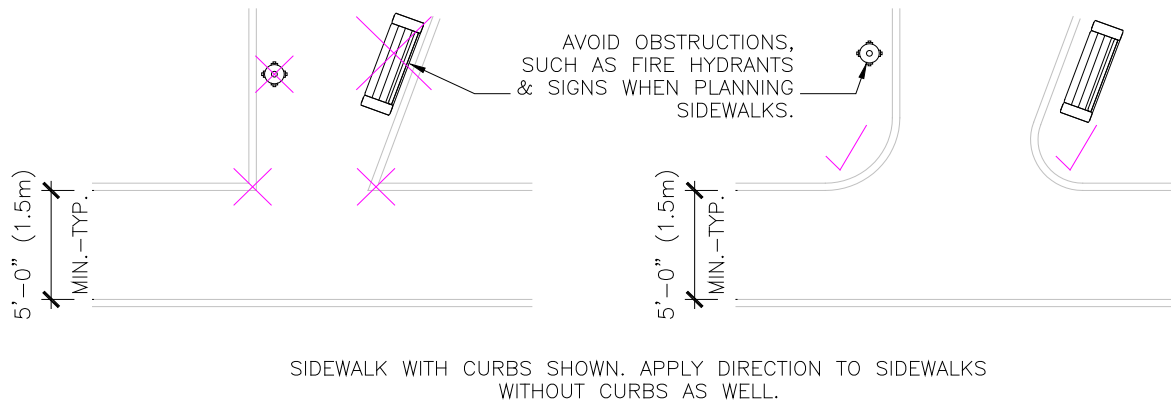

Figure 5.1.3-A

Due to the extremes of climate found in Lethbridge, it is essential that the steel reinforcement in sidewalks be correctly installed. It must be maintained at 1/3 of the distance measured from the concrete sidewalk base. Rebar pushed to the bottom of the pour will not be acceptable.

A 2.44m (8 ft.) minimum clearance is required above sidewalks to allow for grounds equipment to be used in those locations.

Bicycle paths, racks and/or storage are to be part of the landscaping design of any new building.

Where applicable, exterior handrails are to be placed at the sides of concrete walls, not on top of the walls. This placement reduces the degradation of the materials.

Plantings

Non-native plants detract from the natural landscape surrounding. The objective is for all the buildings and the surrounding site to blend in and enhance the natural coulee setting.

Plant selection should give consideration to the characteristics during the seasons that the academic semester occurs; fall to spring. Elements to consider include; fall colour, bark texture and colour, branching pattern, flowering period and colour, coniferous or deciduous and leaf out time in spring.



A consistent tree planting strategy at the campus gateway along Aperture Drive and alongside significant spines will enhance place making and wayfinding on campus.

Existing plant material that is within the boundary of construction projects shall be maintained or replanted elsewhere whenever possible. Plant material and trees that may be affected by construction shall be protected and removed before the risk of damage is present.

Plans for new plant species and existing plants to remain shall be approved by the Grounds Manager and Project Manager and examined at all stages of removal and installation.

All sites are to be designed for public and personal safety. The use of dense landscape screens, such as tall hedges, solid fences and long fencing lines that could act as entrapment areas and regions of limited visibility are to be avoided in accordance with CPTED guidelines.

The following should be considered when specifying plant material:

- Avoid planting trees too close to buildings by providing appropriate space between a building and mature tree spread to accommodate building maintenance equipment such as swing stages or overhead utility lines.
- Avoid the use of turf on steep slopes where maintenance is difficult and dangerous. Native drought tolerant plants should be placed in sloped areas.
- Choose appropriate plant material and mulches in areas that are exposed to extreme wind to avoid mulch that will blow away, plants that will desiccate or shrubs and other plants that will collect litter.
- Plants must suit the intended uses of the area and irrigation regimen planned for that area. Low maintenance regions will require drought tolerant plants while high traffic regions will require more vigorously growing plants and higher irrigation rates.
- All plants used in this landscape must be proven performers in our soil, our climate and our traffic conditions. Whenever possible, choose plant species found within 100 kilometers of Lethbridge as a method of ensuring that these species will be suitable to our growing conditions.
- Avoid plants with high maintenance needs such as pruning, fertility, disease, pests, irrigation, drainage, dropping of leaves, needles or fruit, etc.
- Plantings need to take location into account for issues such as wind, sunlight and shade, drainage, capacity for creating or catching litter, fruit or leaf production, attraction to nuisance insects or animals, sight lines on campus for both pedestrian and vehicular traffic, summer and winter appearance, disease resistance, drought tolerance, flood tolerance, snow drift creation, natural size of plants, maintenance requirements and past performance of species on campus.

For irrigation installation standards and previously approved manufacturers, please refer to information provided in the appendix.

Related Documents

[http://www.canadanursery.com/Storage/47/5649_CSNS - 8th Edition - web.pdf](http://www.canadanursery.com/Storage/47/5649_CSNS_-_8th_Edition_-_web.pdf)

5.1.4 Firefighting Access

Practices

Provide unobstructed firefighting access to all buildings and public campus areas to ensure life safety of occupants and the adequate access and protection of campus assets.

Due to the nature of the coulee setting, some building sites are not easily accessible from all sides or elevations. To the maximum practical extent, practices to be considered include consideration for various types of requirements for firefighting access as a result of fire situations within or around buildings (including potential prairie fires originating elsewhere).

Related Documents

University Hall – Building Code and Life Safety Review (2009), Sereca Fire Consulting Ltd.

5.1.5 Vehicular Circulation and Parking - Roads, Paving and Walks

Practices

Due to an increase in automobile commuters, transit users, pedestrian and cyclists, and an increase in on-campus residents, vehicular access will be restricted from areas of the core academic campus.

Larger parking lots are located at the campus periphery. Smaller parking lots are strategically scattered throughout campus for short-term parking needs providing convenient accessible parking adjacent to main access points.

Although vehicular traffic is restricted from the campus core, service and emergency vehicles have full access to all campus facilities. Access would be along specially widened pedestrian walkways also designed to accommodate service and emergency vehicles.

Barrier free access to sidewalks at road crossings should be located at corner and mid-points of dedicated walking surfaces when long sidewalks present additional barriers to less able-bodied persons. Bicycle paths, racks and/or storage to be integrated as part of the landscaping and architectural design of any new building.

Where applicable, exterior handrails are to be located to assist pedestrians, preferably mounted at the sides of concrete steps and walks, rather than embedded in the top of walking surfaces which create durability and maintenance issues.

5.1.6 Pedestrian Surfaces

Practices

The design of all pedestrian surfaces and areas are to be fully integrated with adjacent buildings and overall site development on campus in order to provide a consistent material vocabulary and pedestrian-friendly campus.

Paved surfaces on site should be accessible by all users and be designed in accordance with the Alberta Building Code and Alberta Barrier Free Guide. Paving shall be designed with the flow of traffic in mind, with consideration for 'shortcutting' and damage to landscaping.

Paving material to be selected should give consideration to drainage and be easy to plough.

Acceptable pedestrian paving materials include:

Primary pathway surfaces:

- Concrete with light sandblast finish pattern
- Coloured concrete
- Unit pavers with concrete edger
- Appropriate stone or precast concrete elements

Secondary pathway surfaces:

- Concrete with broom finish pattern
- Asphalt with concrete edges
- Durable wood surfaces (limited use)
- Tertiary pathway surfaces (trails, etc.)
- Asphalt
- Crushed local rock material

Prohibited pathway materials:

- Ceramic or glazed tile (including within building entrances).
- Rubber or plastic (PVC) pavers.
- Excessive painting as the primary visual cue.

- Woodchip or bark paths.

All concrete surfaces are to integrate expansion and control joints which are to be smoothly tooled and located to effectively manage cracking. An initial broom finish should extend the full width of the surface from edge to edge, preventing a trowelled appearance at joints and, optionally, lightly sandblasted.

When installing new pathway systems or improving existing pathways, way-finding signage, seating elements, lighting and weather protection should be thoughtfully considered.

Where pedestrian pathways meet roadways, passable barriers (e.g. of sufficient width or by telescopic bollards) shall be installed in key locations around the pedestrian core to provide access for emergency, security and authorized vehicles while limiting access by other vehicles. Discretion should be used to prioritize pedestrian movement with grounds maintenance. Snow removal equipment typically requires 1.85m clearance, where warranted.

Incorporate curb cuts and wheelchair ramps in paved areas to accomplish the goal of providing a barrier-free campus accessible by all people. To accommodate for changes in grade, ramps shall be used instead of steps whenever possible. Visual indication of excessive changes in grade should be made evident in accordance with universal design standards by using contrasting materials or trowelled demarcation lines.

Paving and walkways should be wide enough to permit ease of snow removal equipment and limit hand shoveling. A clear, unobstructed distance of 1.5 m from obstacles to the outside edge of sidewalk is ideal. Where possible, site elements such as signage and fire hydrants are not to intrude on dedicated pedestrian surfaces.

Related Documents

[Alberta Barrier-Free Design Guide](#)

5.1.7 Site / Building Lighting & Power

Practices

All exterior lamps shall be base mounted ballasts (as applicable) and consider energy efficiency, efficacy, environmental effects of light pollution, colour index (+/- 4,100k) and be LED or Metal Halide.

Building lighting should be used to highlight building entrances and architectural elements and consider the effects of glare and the impact of overall energy use and maintenance.

All outdoor lighting shall be controlled by BMS. As applicable, photocells shall be placed to provide optimum energy use and for security considerations.

Power receptacles to be integrated into public areas through pedestals or design elements to enable events is warranted on a project by project basis.

5.1.8 Exterior Campus Environmental Signage

Practices

To express the culture and vision of the University of Lethbridge, a way-finding system was implemented in 2002. The system provides orientation and direction of form and function in an aesthetic package that gives the campus a consistent visual identity through simple graphic communication and design.

All new signage must comply with our established standards for design, manufacture, installation and maintenance. All signage is to be approved for implementation by Campus Development.

Related Documents [University of Lethbridge Campus Sign System](#)

5.1.9 Site Furnishings and Fixtures

Practices

New projects flanking ceremonial routes in public areas will include furnishings, lighting and banner arms along the length of the route or building façade.

The choice of materials for site furniture shall invite use and be comfortable regardless of the time of the year. Winter conditions can make some materials, like concrete, finished metal and enameled steel, unpleasant to use. Seat surfaces and vertical supports shall be designed to avoid accumulation of snow and debris. Seat surfaces should be pitched slightly to shed water away from walking surfaces where wetness or ice may create additional hazards. Benches should be skateboard proof and where appropriate, visually contrast with the surrounding area so that persons with visual impairments can locate them.

Bollards shall be placed to minimize obstruction to pedestrian flow while defining boundaries for controlled automobile traffic. The minimum clearance between bollards shall be 1200mm with a minimum height shall be 450mm and contrast in colour from the surrounding paving to be more visible. Chains, cables or ropes are discouraged as permanent or temporary barriers unless they are easily visible. They must be placed at a height that can be detected by the visually impaired.

Trash containers should visually integrate with their environments and be located adjacent to, but not obstruct, walkways. Trash container designs shall include ease of use and exclusion of rain and snow within bins. They shall be operable with one hand and be of accessible height for disabled persons. Ideally, opening flaps help to mitigate wasp nests and scavenging birds which others can create safety concerns and additional grounds maintenance.

5.1.10 Storm Water Management

Practices

Surface and subsurface considerations should be made for proper grading and drainage of storm water around buildings and through public spaces in the event of significant rainfall or heavy snow melt.

The consultant in conjunction with the Grounds and Utilities Department will determine the location of storm water drainage paths and below grade service tie-ins. All tie-in methods must be approved by the Utilities Department.

University of Lethbridge will inspect and camera all building weeping tile conduits prior to burial. Adequate cleanouts for weeping tile systems to be provided so all areas can be inspected with camera. On straight runs cleanouts to be spaced 25m apart. Bends or corners in weeping tile require additional cleanouts.

5.1.10.1 Water Supply

Practices

The consultant in conjunction with the Utilities Department will determine the locations of domestic water service tie-ins. All tie-in methods must be approved by the Utilities Department. Domestic water service is treated and provided by the City of Lethbridge and integrated with campus facilities.

Fire Hydrants in use on campus are Canada Value Century.

5.1.10.2 Storm Sewer

Practices

The consultant in conjunction with the Utilities Department will determine the locations of storm sewer service tie-ins. All tie-in methods must be approved by the Utilities Department.

5.1.10.3 Sanitary Sewer

Practices

The consultant in conjunction with the Utilities Department will determine the locations of sanitary sewer service tie-ins. All tie-in methods must be approved by the Utilities Department.

Pipe Clamps for above grade sanitary and storm drains in use on campus are Fernco or MJ clamps.

5.1.11 Site Civil/Mechanical Utilities

Practices

All surface and underground works, unless otherwise noted herein, should be in accordance with the City of Lethbridge Infrastructure Services Construction Specifications.

Manhole covers are to be identified by cast-in language indicating “storm sewer” and “sanitary sewer”.

5.1.12 Site Electrical Utilities

Practices

Locates for below grade utilities are to be performed by University Utilities department by work order request.

The Electrical Design Consultant is required to physically examine the site and verify existing conditions and to review the work area. The Electrical Design Consultant shall meet with the University Utilities Electrical Manager to develop and prepare a program and layout for all new buildings and renovations.

5.1.13 Natural Gas

Practices

Buried natural gas lines are to have tracer wires installed.

5.1.14 Irrigation

Practices

Buried irrigation lines are to have tracer wires installed.

5.1.15 [Reserved]

5.2 Structure

5.2.1 General Requirements

Practices

Structural information must adequately describe the design requirements in the construction documents. There should be little interpretation left to the contractor as to what the design intent and specifications entail while balancing an acceptable level of detail.

Drawings should be consistent with the University’s general drawing standards identified earlier in this document.

5.2.2 Structural Drawing Requirements

Practices

As a minimum, the Construction Drawings should indicate the design intent with the following information:

- Structural layout of the overall foundation system, floor framing plans and roof framing plan.
- Providing an identical grid system, coordinated with the architect's building design layout, complete with grid dimensions, is encouraged to facilitate consistent reference to the plans.
- Structural drawings are to provide adequate dimensions relating to their discipline in order for the proper coordination of structural elements to occur.
- The foundation plan should include an applicable piling, grade beam, wall and footing schedule. Other applicable schedules or designations on the plan should be referenced back to the schedules contained on other sheets.
- The foundation plan, schedules or general notes shall document the criteria used in design, such as the bearing pressure and engineered fill requirements. Size and location of all structural framing components for the primary building structure must be shown for each direction and at all levels of structure. Indicate location of each lateral force resisting component such as, but not limited to, lateral bracing, shear walls, moment frames, etc.
- Include sufficient detail cuts, references to schedules and specific information identifying the primary structural components.

The following minimum structural drawing information should be identified under reference notes in the documents:

- Loading and basic design criteria.
- Material stresses used in design.
- Deferred Submittal information; and
- Other structural requirements as they pertain to the primary building structure.

Primary Structural Component connections required to transfer gravity load from roof to floor to foundation must be detailed. These connections would include, but are not limited to, joist to beam or wall, beam-to-beam, beam to column and column to foundation.

Details must be shown for all lateral force resisting connections. These types of connections are; diaphragm shear transfer, out of plane anchorage, bracing connections, moment frame connections and force transfer to foundations. Structural detailing of Secondary Structural Components such as parapets, fasciae and canopies must be included in the structural drawings and coordinated with the architectural design.

5.2.3 Foundations

Practices

All construction shall employ the services of a Geotechnical Engineer who will perform an analysis of the existing site along with recommendations for possible building foundations in coordination with a Structural Engineer.

As appropriate to the foundation type and scale of structure, the foundation perimeter must be surrounded continuously by drainage tile and terminate within the crawlspace(s) at zoned sump pits.

Depth of frost protection for footings shall be not less than 1200mm for heated structures, and not less than 2100mm for unheated structures unless otherwise recommended by the geotechnical consultant.

Due to a high-water table, all foundations will require continuous water or damp-proofing and drainage mat.

5.2.4 Concrete/Masonry

5.2.4.1 Design

Practices

Masonry, associated components, and all materials in the wall assembly behind masonry shall have a design service life of at least 100 years (excluding surface cleaning maintenance).

Window and door installations should be designed to allow replacement of the units without dismantling masonry or concrete.

Coordinate masonry or concrete wall system design with the Building Envelope Consultant, as appropriate.

Reinforcing and other steel requiring corrosion protection shall be embedded to a professionally acceptable minimum depth of mortar, grout, or concrete cover. Stainless steel is to be used where reinforcement or other embedded metal has limited cover.

Masonry shall be structurally supported to resist maximum wind loads, 30-year return. The structural back-up wall for masonry veneer shall resist 1 in 30-year return design wind loading with a maximum deflection of $L/360$.

Shop drawings must be submitted for all masonry supports and ties. Mock-ups of all assemblies should be constructed to verify contractor's procedures and establish a benchmark standard of construction.

5.2.4.2 Mortar and Grout

Practices

Mortar ingredients shall consist of Portland cement, sand, hydrated lime, potable water, and inorganic, non-staining, non-fading pigments. The use of calcium chloride or admixtures containing calcium chloride in mortar is not permitted.

5.2.4.3 Masonry Accessories

Practices

All masonry accessories to have design service lives compatible with masonry or stainless-steel two-part ties.

Structural steel employed in the support of masonry and in the wall cavity shall be hot dip galvanized or stainless.

All flashings and other waterproofing accessories in the wall cavity shall be designed for a service life of 100 years. Materials considered capable of this service interval are:

Neoprene rubber sheet.

Thermo fusible SBS modified asphalt roofing membrane, fully reinforced, and fully bonded to substrate.
Asphalt modified urethane coating, fully reinforced, and fully bonded to substrate.

Where a galvanized steel or aluminum surface will be in contact with mortar or masonry, the metal shall be over coated with a layer of bituminous or other equivalent barrier material bonded over 100% of its surface area.

5.2.4.4 *Finishes*

Practices

Surfaces of exterior masonry to be treated with a clear silane/siloxane type sealer after final cleaning.

Surfaces of exterior masonry near grade to be treated with a clear anti-graffiti type coating to a minimum height of 2440mm (8') where required by the University. Anti-graffiti coating systems with a wax top coat are preferred.

Acids are not to be specified for cleaning masonry or pre-cast concrete without prior written approval.

5.2.5 *Floor Construction Assemblies*

5.2.5.1 *General Requirements*

Practices

Define fire separation requirements of floor assemblies in relation to adjacent occupancies by including a Building Code Summary in construction drawings.

Coordinate floor assemblies with the architectural concept with exposed structures where possible to eliminate unnecessary finishes.

The architect and structural engineer shall coordinate the planning and design of floor to floor and overall building height to accommodate mechanical ventilation and piping system routes in an integrated strategy.

5.2.5.2 *Flat Slabs on Grade*

Practices

Slabs on grade are to be a minimum 150mm thick, reinforced and provided with optimally space control joints.

Appropriate vapour barrier is required; perforating vapour barriers to avoid "slab curling" is not acceptable.

Slabs-on-grade require appropriate rigid insulation. For existing concrete slabs, the maximum level difference shall be 3mm per 1m.

Exterior concrete steps must have a minimal slope of 0.5% toward the downward direction of the stair to allow for sufficient water drainage and to prevent ice formation.

5.2.6 *Vibration*

Practices

Floor vibrations arising from normal human activity and the operation of mechanical equipment may affect the serviceability of modern building structures, which are becoming lighter and more flexible. Efforts to minimize floor vibrations that are objectionable to building occupants through structural design include a static deflection check, in which the deflection limit depends on occupancy type as well as span as well as other structural design approaches that limit vibration transfer through a building.

Additionally, laboratory spaces often have sensitive equipment that can detect building vibration which interferes with experimental research and data collection.

5.2.7 *[Reserved]*

5.3 Building Envelope Systems

Provide complete building envelope systems that address the life cycle, durability, maintenance and overall thermal, air tightness and moisture management performance of wall, roof and slab systems which provide continuity of assemblies and reduce long term operating costs.

5.3.1 *General Requirements*

Intent

Devise architectural façade concepts that are technically feasible and integrated with principles of environmental design including appropriate responses to building and solar orientation, high window performance, continuous air and liquid moisture and vapour barrier systems, pressure equalized rain screen design, passive solar, hybrid and active systems.

The architect, in coordination with a building envelope specialist and mechanical engineer, must be involved in the design of the building envelope and related mechanical systems. Where possible, buildings should first be designed with only the necessary dependence on active mechanical systems for the specific building design.

5.3.2 *Thermal and Moisture Protection*

5.3.2.1 *Insulation*

Practices

Insulation levels providing thermal resistance to outdoor environments should exceed minimum code requirements at roofs, exterior walls and below grade. Detailing of components should address paths of water migration toward the exterior face and insulate building structural components that transition from the outside to the interior.

Where feasible, insulation levels should meet the following minimum requirements:

Perimeter application at foundation below grade: RSI 2.1

Exterior walls: RSI 3.4

Roofs: RSI 5.8

To mitigate thermal bridges through conductive materials, adequate insulation (minimum RSI 0.88) is to be provided between any exterior building cladding component and its structural support member. Insulate to the outside of all building structural components, including columns, beams, lintels and purlins (minimum RSI 3.4) in consultation with architect and envelope consultant.

Insulation should be secured mechanically so that it is in direct contact with the outside surface of the air barrier system. Locate insulation to the exterior of structural elements to completely enclose non-cladding components of the envelope and to reduce thermal transfer or the effects of bridging and potential areas of condensation within the envelope system.

Insulation is to be mopped, adhered, and or mechanically fastened as required to meet wind uplift standards, manufacturer and warranty requirements and as appropriate to the configuration of the building.

5.3.2.2 Membrane Waterproofing

Practices

All installations must meet the approval of the University of Lethbridge Building Envelope Commissioning Team.

Wherever possible, locate the air vapour barrier membrane (AVBM) exterior to structural elements. All air/vapour barrier membrane installations shall be orientated according to manufacturer's specifications, typically vertically to avoid 'fish mouths' at lapped seams that provide a means of water intrusion into wall cavities. In all circumstances the air/vapour barrier shall overlap the foundation wall a minimum of 150mm.

All joints must be overlapped to manufacturer's specification (minimum 150mm) and rolled to eliminate all creases and as per the installation manual.

At joints within materials and components and at junctions between assemblies (i.e. walls to roofs and windows to walls), provide suitable detailing to ensure continuity of the air barrier with consideration for differential movements and construction sequencing. Minimize the number of materials used to form the air barrier system by simplifying the number of transitions or changes of plane and other mixed approaches.

Consider the need for compatibility of materials in contact with one another and utilize manufacturer's products and systems consistently and compatibly.

5.3.3 Roof Systems

5.3.3.1 General Requirements

Roofing systems are to include all related assembly components, fasteners, adhesives, cover boards, underlays, insulation, membranes and all roof related hardware and flashings as appropriate to the building and as specified. In addition to the above in the case of re-roofing, the assembly shall include wood blocking additions and/or modifications as required to meet the requirements of the new roofing assembly.

All new roofs shall carry a minimum 25-year warranty and be constructed with a minimum thermal resistance rating of R40. Assurance of warranty required prior to installation and proof of warranty required upon project completion.

Install roofing only when weather conditions permit. Stored materials that become wet due to improper storage in inclement weather shall be replaced at no expense to the Owner. In the case of re-roofing, the replacement roofing and building shall be sealed and rendered watertight at the end of day.

Structural designs for roofs must proceed with regard to possible future use as platforms for equipment such as antenna, receivers, and observation areas, as well as the possibility for use of staging or lay-down during building renovations. Areas so designed must be clearly identified on the structural and architectural plans.

All roof drains shall be cast iron dome type. Roof drain bowls/bodies are to be insulated at time of roof drain insulation. Roof drains and hatches require submittal of shop drawings for approval by Building Maintenance. Roof hatches are to have a fixed railing system or other permanent means of fall protection within openings. Roof hatches are to have a minimum insulation value of RSI 3.5 with latch designed for one handed release.

All roof drainage to be coordinated with Facilities. Where roof drainage is to grade, locate outlets and interior drainage pipes which discharge to the outside at a location sufficiently above grade so as to preclude damming and backup into the building. Where drainage is not to be handled on site, rainwater leaders are to be taken through the interior and tied to the storm sewer system. Avoid the use of scuppers except as emergency overflow devices.

When light is to be introduced through the roof, use vertical clerestory glazing or roof monitors in lieu of skylights and sloped glazing. Any use of skylights, light tubes or sloped windows requires approval from the University.

Roofs are to be provided with access from the interior of the building wherever possible. Exterior roof access ladders are to have enclosed safety cages with graspable safety posts and foot pads to be used when accessing the roof and unlocking or securing roof hatch padlocks. Install walkway pads at all access door hatches, around all rooftop mechanical and other equipment that requires regular maintenance and all leading areas to main roof access points, ladders or hatches.

5.3.3.2 Low-sloped Roofing

Practices

Roofing is to be designed to wind uplift standards that respond to our high wind conditions in southern Alberta (minimum Class 1-90 windstorm).

The design service life of low-sloped roofs must be a minimum of 25 years. New and re-roof assemblies shall have an absolute minimum 2% slope "to drain". Roofing is to be designed to minimum Factory Mutual wind uplift standards, Class 1-90 windstorm.

The installation of concrete or asphalt topping over membrane roofing is not permitted without prior approval and written confirmation.

Vapour retarders are to be included in all assemblies and shall be fully adhered to the substrate. Products shall be appropriate to the building envelope configuration and be installed to wrap and envelop the insulation, be compatible for connection to the building envelope air barrier and be sealed at all penetrations.

Where a roof joins a wall that is extending above the roof, locate wall cladding, windows, doors, louvers and other wall penetrations a minimum of 300 mm above the top surface of the roof.

Roofing connections to walls are recommended to be designed as protected membrane transitions in both conventional and protected membrane designs.

Maintain a constant elevation around the perimeter of the contained roof area. If a varying perimeter cannot be avoided, provide dimension details of low and high edge conditions.

Install walkway pads at all access doors and hatches, around all rooftop mechanical and other equipment requiring maintenance and, from there, leading to the main roof access stairs, ladders, or roof hatch.

5.3.3.3 Membrane Roofing

Practices

Elastometric membrane roofing shall be an electrometric modified bitumen fully adhered roof type.

Thermoplastic Membrane shall be thermoplastic polyolefin membrane roof type.

Adhered thermoplastic polyvinyl chloride (PVC) or thermoplastic polyolefin (TPO) single-ply membrane roof systems are not permitted. Tremco's Tremline Roof Assembly (TRA) single ply roofing system has a history of performing best on campus.

5.3.3.4 Sheet Metal Roofing

Practices

Metal roofs should be considered as water-shedding only. The provision of membranes under all metal roofing and flashings are to be considered as "water shedding" rather than "waterproofing".

The air barrier system in a sheet metal roofing system is to function as a secondary drainage plane. All fastener penetrations are to be sealed and clamped, and the air barrier plane is to be water tight over the design service life of the roofing. Sheet metal roofing systems are to be the concealed fastener type.

The design service life of sheet metal roofs is to be a minimum of 30 years to first major maintenance/replacement and an effective weather tightness guarantee covering a 10 year period.

Differential thermal movement between the panels and the purlins/joists should be permitted throughout a temperature range of 100°C.

5.3.3.5 Sheet Metal Flashing & Trim

Practices

Wherever possible, avoid exposed surface type fasteners or the use of a reglet as a roof membrane termination or transition. Apply asphaltic coating to all metal surfaces in contact with cementitious materials.

Provide a 10% slope toward roof surfaces at all parapet flashings and minimum 2% slope elsewhere. Cap flashings to be a maximum of 1200mm lengths to protect against wind uplift or damage.

Roofing is to be designed to meet Guarantee Standards of the Alberta Roofing Contractors Association (ARCA) and follow all minimum recommendations as published in the Roofing Application Standards Manual.

5.3.4 Exterior Wall Systems

Practices

The recommended envelope design approach for campus buildings is a "pressure equalized rainscreen" and insulated structure technique". This approach is characterized by the following:

- Exterior cladding covering an air space, pressure equalized with the exterior environment.

- An adhered air sealing component to the exterior of structural frame and structural infill. The air sealing component in combination with the underlying structural elements forms the air barrier system.
- Insulation in direct and firm contact with the air barrier system.
- Materials used should be suitable for the environmental conditions and should provide a service life consistent with the planned building life. Consider accessibility for purposes of maintenance of the building components.
- Provide suitable drainage and venting to minimize moisture, drain moisture adequately and quickly dry areas that become moist.
- Elements that penetrate the building envelope should be avoided. Where they occur, thermal separation and control will be necessary, as will considerations for membrane and air barrier integrity.
- Where detailing for exterior envelope finishes appear to continue to the interior, an appropriate seal at the breakpoint of transition will be necessary.

5.3.5 *Materials*

Practices

All finishes should comply with materials approved for use and the intent of the Campus Master Plan and ultimately be approved by the department of Campus Development.

Consider adjacent buildings when selecting cladding materials and colours. For building additions, develop schemes that use complementary cladding materials.

Enclosure assemblies are to be coordinated with technical efforts to maintain air tightness, drainage, venting, and thermal resistance. Cladding systems are to:

- Be detailed to ensure that water, snow and ice sheds safely from exterior surfaces, and are not trapped in the assembly to cause deterioration or excessive weathering of finishes.
- Be integrated with the design of windows, doors, flashing and other penetrations.
- Cavities built behind the cladding shall be drained and ventilated to the exterior.
- Should have impact protection up to a minimum of 2.4 m above grade.
- Be designed as weather tight under sustained conditions of combined wetting and 50 Pa wind pressure.
- Be designed to resist expected wind loading and lateral and vertical deformations of the primary structure without loss of attachment to the building.

Limit the use of paint finishes on exterior wall assemblies to the fullest extent. Exterior pre-finished elements should have a powder coated or enameled finish that will withstand the elements and limit maintenance requirements. Do not use water-based paints formulated with aromatic hydrocarbons, formaldehyde, halogenated solvents, mercury or mercury compounds, or tinted with pigments of lead, cadmium, chromium VI and their oxides. Water based paints shall be low VOC and shall have a flash point of 61 degrees Celsius or greater.

Where it is necessary to use solvent-based paints, they shall be formulated with low VOC emissions and shall not be compounds, or tinted with pigments of lead, cadmium, chromium VI and their oxides, nor formulated with more than 10% aromatic hydrocarbons by weight.

Paints applied to exterior elements should be of premium grade selected from the University's MPI Painting Manual for Interior/Exterior Paints.

Related Documents

MPI Painting Manual for Interior/Exterior Paints (UofL Paint Spec – New Buildings)

5.3.6 Fenestration

5.3.6.1 General Requirements

Practices

Fenestration design should not exceed a 40% window-to-wall ratio for our winter climate. For south and west exposures, consideration should be given to additional shading treatments such as vertical or horizontal shading devices, brise soleil, or tinted glass. Coordinate glazing with the lighting and mechanical systems to avoid glare and solar overheating.

Wherever the site topography makes windows difficult or nearly impossible to replace or repair, windows must be able to be changed out from the building interior.

All windows and window assemblies are to be designed according to the pressure equalized rain screen principles of the envelope system. Fenestration is to incorporate air seals at a protected location in the assembly, with drained and ventilated compartments behind the exterior weather seals. The main mass of the frame is to be located to the interior of the thermal break.

Exterior glazing minimum shall be insulating sealed double-glazing units, except for structural glazing requiring single glazing. Component design to maximize energy performance as established by the Project Criteria, including orientation and expected functional use of space in which glazing occurs.

Clear float glass, regardless of thickness, shall not be used for any installation, interior or exterior, in single pane applications. This includes borrowed lights, transoms, sidelights, doors, display cases and other miscellaneous windows. Windows shall be double, or triple glazed insulated units.

Use wired/fire glass only where required for fire rating.

Low E glass should be considered for all conditions. Sealed double glazing is generally to include high performance Low-E coating on appropriate surface as recommended by manufacturer for level of performance indicated, as different manufacturers place their coatings on surface #2 or #3 depending on desired end result and resulting performance characteristics. Tinted glass should not be used for windows at grade.

Design window and interior surrounds to allow uniform air movement across the glass and frame. Insulated glazing units are to be selected with a 10-Year warranty also to cover inter-pane dusting or misting. Window installations need to accommodate building movements.

Thermal transmittance and solar heat gain coefficient for windows are to be selected in coordination with mechanical consultant and to be coordinated with project sustainability goals. Full window (not center of glass) U-values should be less than 2.3 W/m²-K, Solar Heat Gain Coefficient (SHGC) values should be less than 0.40, and Visible Transmittance (Tv) should be greater than 0.40. All sealed units are to incorporate non-metallic (warm edge) spacers.

Building design should make provision for window washing and other maintenance access to both sides of glazing units.

Frames are to be glazed with internal removable stops or by using tamper-proof fasteners where security is required. Frames need to be supplied with receiving surfaces for sealing to air and vapour barrier materials, insulation, and cladding in the wall assembly. Sound attenuation ratings for windows to be selected based upon interior requirements. Frame materials to be selected for a minimum 30-Year service life.

Hardware and seals of operable units should be designed so that hardware can be adjusted, and seals maintained or replaced over the life of the window to maintain air and weather tightness. Immediately remove sealant and compound droppings from finished surfaces. Remove labels after work is completed.

Suitable frame materials include anodized aluminum with corrosion protection or pultruded fiberglass frames. Choose window frames that will assist to prevent condensation from forming on the frame at the interior face during January design temperatures.

Windows manufactured of PVC, CPVC, or FRP are not acceptable. Wood windows are not permitted in non-residential buildings or residential buildings taller than three storeys in building height. A review of the window selection and written approval is required prior to a consideration of frames of wood or PVC materials.

Sill accessories and flashing material shall be tied-in and connected with waterproof lap joints or shall be under laid with continuous secondary back-up waterproofing. Joints shall remain waterproof while accommodating thermal movement for the life of the installation. Exterior sills and flashings are to be installed with a definite outward slope (15° degrees or more).

Setting blocks and shims are to be neoprene (rather than wood or other organic materials).

5.3.6.2 Aluminum Window & Curtain Wall Frames

Practices

Exterior systems are to utilize exterior rain screen deterrents, interior air seal barriers, and cavities pressure-equalized to the exterior to minimize water infiltration into the internal areas of the system, assembled and installed to provide control and drainage to the exterior of any water which enters the pressure-equalized cavities.

Wind loads shall be addressed as assemblies, reinforced where required, capable of withstanding local positive and negative wind pressures. Assemblies are to support design loads and accommodate structural deflection and long-term creep movements and drift without stress on glass, buckling, failure of joint seals, undue stress on structural elements, damaging loads on fasteners, reduction of performance, or other detrimental effects caused by structural movement.

The connection of windows and window framing to the structure of the building is to be detailed in such a way that only horizontal and vertical forces are transmitted. No bending moments to be applied by the curtain wall to the structure or structural support.

Before installation, ensure that an applied air barrier membrane (or equivalent) is installed to drain to exterior, over the entire perimeter of the opening over which the framing system is to be installed.

After installation and before installation of sealants, apply spray-in-place polyurethane insulation conforming to current relevant CAN/CGSB standard, to fill and seal all joints.

5.3.7 Exterior Doors

Practices

Location of exterior entrances should be designed with accessibility, safety and weather protection in mind. A west or north facing door should be avoided as much as possible to avoid operational, safety and maintenance issues that are caused by strong west winds. Overhead canopies or set back entrances may be necessary at some exterior doors.

Water tightness rating for exposed doors to be selected based upon exposure to elements related to location on the façade and site conditions. Exposed doors and frames are to be designed to incorporate air seals at a protected location in the assembly, and drained and ventilated compartments behind the exterior weather seals.

Pressed steel or extruded aluminium: design large entrance openings with structural steel sub-frame assemblies. Consult with the Project Manager for special glazing requirements (wire glass and Plexiglas) where sidelites to entrance doors are being considered. Wood doors are generally not permitted.

Frames are to be glazed with internal removable stops or using tamper-proof fasteners where security is required. Provide glazed exterior doors and/or side lite. Tempered glazing is required in all sidelites and partitions within reachable limits of floor to door height or standard ceiling throughout.

All exterior doors are to have aluminum thresholds set in a bed of mastic and screwed to the substrate. Door sills need to be integrated with terminations of roofing membranes where applicable.

All exterior and inner vestibule doors are to be insulated, thermally broken and weather stripped. Door sweeps and thresholds are required for all exterior doors.

Existing doors that are non-code compliant should be reviewed with the code authority prior to reuse.

5.3.8 Door Hardware

Practices

Provide automatic door operators at barrier free entrances. At high volume (primary) entrances consider the viability of sensor-type operation. Activating devices are to be 100mm diameter push button plates mounted to wall, frame or guard rail with standard handicap symbol.

Frame-mount door closures on interior side of door rated for heavy traffic. Finish to match other hardware.

Standard door hardware finish for all installations shall be clear (613, US10B, etc.) for all components. Where alternate finishes are proposed, prior approval from Building Maintenance (Lock Shop staff) is required.

Maintenance staff require key overrides regardless of keying type. A minimum of two (2) keys shall be supplied per cylinder. Except for major projects, cylinder installation is typically coordinated and performed by the Building Maintenance department.

All finish hardware shall be guaranteed against any defects in design, materials, finish, function, and workmanship. The guarantee is to be by the hardware manufacturer with a written certification from certified date of substantial performance as follows:

- Finish hardware (excepting door closers, exit devices, and butt hinges) for a period of two (2) years.
- Door closers for a period of ten (10) years.
- Exit devices for a period of three (3) years.
- Activator buttons for a period of one (1) year.
- Butt hinges shall carry a lifetime guarantee.

For acceptable manufacturers and specified standards for all hardware, please refer to the door hardware table (Table 08 06 70-1) located in the Appendix.

5.3.9 Sealants & Adhesives

Practices

The University experiences consistent failures and ongoing maintenance of exterior caulking on door and window frames, cladding joints in face-sealed dry cavity envelope systems. The design consultant is to develop details, specify sealants, and involve manufacturers to obtain high performance, durability, and low maintenance. Quality assurance programs are to be incorporated in the contract documents particular to the project and developed in concert with manufacturers, specialized trades and the envelope consultant. Where renovation and maintenance are the objective, a qualified, restoration contractor is to be used to repair and restore existing sealants in envelope assemblies.

Joint sealants are not to be used as a primary method of waterproofing or shedding water. Appropriate counter flashings and cladding details must be provided. **Caulking shall never be used to hide or make up for design or construction errors or faults.**

Only high-performance elastomeric sealants are to be used. Sealants must be capable of withstanding dynamically moving joints in exterior applications for long periods of time (typically 20+ years). Caulking shall be tooled to a smooth concave finish with backer rod to a maximum 1:3 thickness/width ratio. Where necessary, the colour shall match (or be slightly darker than) the adjacent surfaces and the product and colour should have high resistance to ultraviolet degradation or fading.

All joints that receive sealant are to be designed to be 4 times as wide as the anticipated movement. This should include movement due to thermal expansion and contraction as well as structural movement. This is of particular importance at window and door perimeters.

5.3.10 Fall Protection

Practices

All new building construction shall eliminate fall hazards wherever possible through the building design. This can be achieved through the following criteria:

- All Fall Protection prevention and anchorage systems are to meet the requirements of the Alberta Building, Fire and OH&S Codes.
- Guardrails or roof parapets protecting perimeter edges, and which meet the requirements of guardrails.
- Roof/Ladder access points shall be designed to protect a worker from a fall hazard and/or falling through an opening.
- Mechanical Units shall be located within buildings. Where this is not possible and a guardrail or parapet is not used on a roof top, a worker shall not be required to be within 2m of the roof edge to perform work.
- Where workers are exposed to a fall hazard, a fall protection system shall be installed suitable for 2 workers at maximum load of 310 lbs. each (inclusive of equipment/tools) and shall allow for continuous connection over single point anchors and be designed and utilized as a Travel Restraint and Fall Arrest.

5.4 Interiors

5.4.1 Partitions

Intent

Partitions are to be structurally sound and meet acoustical and fire safety requirements.

5.4.1.1 *Block Masonry Partitions*

Practices

Standard concrete masonry block units of modular sizing are to be used. Provide special shapes inclusive of bull nose units for exposed (outside) corners and purpose-made shapes for lintels and bond beams and other special shapes as required to suit specific partition installation requirements.

Incorporate masonry partition where:

- High levels of resistance to impact or abuse (back-of-house, loading and receiving and other ancillary locations) is required.
- High acoustic separation is required (STC 55 or higher).

5.4.1.2 *Steel Stud and Wallboard Partitions*

Practices

Sound Transmission Co-efficient (STC) ratings should be noted on drawings under partition types and provided in accordance with occupant or room requirements.

Incorporate deflection tracks and channel stiffeners as required to suit specific partition assembly installations. Ensure two steel studs are installed back to back at all door jambs to strengthen openings. Steel studs shall be used in accordance with limiting height and deflection requirements. Standard partitions include 25 gauge 92mm steel studs framed at intervals not greater than 400mm on centre for walls up to 3,650mm in height.

Sheathing board applications:

- Standard 5/8" gypsum wallboard for all interior partitions, suspended partitions or walls. Provide non-rated sheathing at typical locations.
- Abuse resistant gypsum wallboard at public corridors, social lounges, entry vestibules and lobbies.
- Water resistant gypsum backing board (light moisture) at typical interior wall applications that receive no direct moisture contact but are in close proximity to high moisture areas for short periods of time (drying areas adjacent to shower enclosures, interior partitions within locker change rooms, etc.).
- Water resistant gypsum sheathing board (high moisture) as a substrate application for adhesion of wall tile and epoxy finishes to high humidity and wet areas such as high moisture content areas (shower and change rooms).
- All wall board finishes are to be set 5/8" above floor.

In areas of high use/abuse such as corridors, service areas and similar usage rooms, provide wall protection at a minimum of 1525mm above finished floor. Acceptable wall protection would include abuse resistant drywall, 19mm plywood, plastic laminate, masonry and/or vinyl/acrylic sheeting. In some locations, the use of bumper rails is acceptable. Provide additional abuse resistance in high impact areas through the use of 1,200mm high wall protection (GIS 19mm plywood and/or plastic laminate panels).

Blocking is to be 19x150mm plywood and provide reinforcement for anchoring of wall-mounted shelves, cabinets, accessibility accessories, window treatments, chalk boards, marker boards, display boards, etc. Locate blocking at 800mm and 1,800mm above finish flooring. Provide continuous solid backing for equipment/fittings/washroom accessories between 900mm to 160mm.

Corner guards are to be stainless steel and have a maximum length of 1525mm and set directly above the base trim.

Gypsum board should be cut and installed to wrap around openings and not align with edge of door or windows. Only paper joint tape (no fibreglass) is to be used.

Related Documents

MPI Painting Manual for Interior/Exterior Paints (UofL Paint Spec – New Buildings)

5.4.1.3 Interior Operable/Demountable Partitions

Practices

Manually or mechanically operated partitions or flat panels should be top-supported with automatic floor and wall seals. Sound Transmission Co-efficient (STC) ratings should be provided in accordance with occupant or room requirements.

Consideration of demountable partitions could be made where flexibility is required. Sound Transmission Co-efficient (STC) ratings should be provided with occupant or room requirements.

5.4.1.4 Fire Separations

Practices

Openings for penetrations in wall assemblies constituting fire separations shall have appropriately rated fire protection (dampers, firestop and smoke sealant) systems installed within the wall assembly or continuously around the perimeter of pipes, ductwork and other mechanical items as applicable. Firestop shall be applied according to ULC listed systems in order to maintain the integrity of designated fire and smoke separations where partitions meet floor and roof assemblies and for all penetrations. Electrical conduits and raceways penetrating floor or wall rated assemblies are to incorporate intumescent fire closure assemblies capable of freely passing IT and telecom cabling. These penetrations are to be incorporated into horizontal or vertical raceway assemblies as a means of maintaining acoustical control and fire separations.

Related Documents

University Hall has the following assessment reports available to guide future work:

University Hall Building Code and Life Safety Review (2009), Sereca Fire Consulting Ltd.
UH Fire Alarm + Compartmentation Strategy Future Works Guidelines (2013), HFKS
Fire Alarm + Compartmentation Strategy – UH Residences (2013), HFKS

5.4.2 Interior Windows and Sidelights

Practices

Pressed steel frames (16 gauge) for interior windows and sidelights are to be fabricated at Canadian Steel Door and Frame Manufacturers Association (CSDFMA) specifications for welded steel frame assemblies.

Aluminium storefront framing at areas of high humidity (e.g. swimming pools) must use thermally broken framing.

Full height frames are to incorporate a 150mm bottom sill minimum. Provide integral or mid rail supports for visual deterrents from pedestrian traffic and/or structural support for glazed panel installations.

PVC, fibreglass or wood framed assemblies are not permitted. Dry glaze interior windows and sidelights with single glazed tempered or laminated safety glass. Wired glass to be used in required fire resistance rated assemblies only.

5.4.3 *Finishing Hardware*

5.4.3.1 *Door Hardware*

Practices

Under the current agreement with the manufacturer, all keys and cylinders shall be shipped directly to the University. The University shall supply a limited amount of construction cylinders for use during construction which must be returned upon completion of the project.

The standard hardware finish is to be dark anodized satin bronze oil rubbed US10B (BHMA 613) or to match existing (renovations).

5.4.4 *Specialties*

5.4.4.1 *Writing Surfaces*

Practices

All whiteboards shall be provided with a lifetime warranty on the writing surface, 28ga porcelain enamel. Warranty to cover any deterioration or defect of the whiteboard writing surface.

Provide whiteboard surfaces in all instructional spaces. Whiteboards shall be fixed to wall surfaces and be mounted 915mm above the finish floor. Whiteboards shall be white and conform to specifications of the Porcelain Enamel Institute. Provide full-length pen-trays under all whiteboards. Do not block electrical outlets or control boxes with whiteboards or tack boards.

Accepted manufacturers of whiteboard products already in use across campus include Shanahan's, Panel Products and CP Distributors.

Tack boards shall be provided in main hallways as directed by Campus Development who will approve placement and number of tack boards to be installed in all new buildings. Tack boards shall be vinyl fabric covered to CGSB 41-6P-30M, Type 3, listed and labelled, weave pattern, 11 mm impregnated sound absorbing fibreboard core and aluminium framing. Tack board trim and framing shall be extruded aluminium, clean anodized with satin finish and it shall be mounted with pan head screws.

5.4.4.2 *Interior Identification Devices*

Practices

The University of Lethbridge has a standard Campus Signage System in place. Consistency in all areas of the campus is important. Building Maintenance staff will coordinate approved designs with Campus Development and install new signage as required in a new or renovated building.

The location of sign panels throughout campus facilities are to include, but are not limited to, the following:

- General building directory plaques inclusive of graphic renderings of facility configurations cross-referenced to directory inventory.
- Way-finding sign plaques, strategically located throughout the facility with subdirectory plaque installations for individual facility zones.
- Fire and evacuation route sign plaques; and
- Wall and door signs for individual room designations.

Interchangeable sign faces: Provide wall signs with approved type, semi-concealed, retaining holders that permit quick, vandal resistant interchange of components. Mechanical means of attachment of signs is required. Anchorage or fastening of sign plaques using contact adhesives or tape is prohibited.

5.4.4.3 Lockers

Practices

Lockers are to be baked enamel steel recessed into wall construction (full height or double tier) with sloped tops. Locking system is to allow use of padlocks. Provide three (3) nickel plated coat hooks, a single shelf in full height lockers and coat hooks in half height lockers.

5.4.4.4 Washroom Accessories

Practices

All washroom vanities shall be provided with an integral backsplash to match vanity surface (plastic laminate, monolithic material, etc.).

Wall mounted toilet partitions are to be prefinished powder-coated steel. Floor, wall mounted, or brace type with superior mounting screws (no tamper proof fasteners) are all acceptable. Ceiling or overhead mounted partitions are not acceptable. Partitions and accessories within wet shower areas should be superior quality stainless steel with stainless steel fasteners.

Blocking is required in walls to properly mount all partitions, grab bars, etc., as required in steel stud partitions.

Washroom accessories shall be wall mounted and not located in counter tops.

5.4.4.5 Safety Accessories

Practices

Other types and locations of wall mounted safety accessories such as First Aid Kits, Fire Extinguishers and Automated External Defibrillators (AEDs) shall be determined by Risk & Safety Services representatives in conjunction with accepted accessibility standards and the Project Manager.

5.4.5 Flooring

5.4.5.1 General Requirements

Practices

Bare concrete floors are preferred in all stairwells, mechanical, electrical, telecom and housekeeping areas, unless otherwise specified. All concrete floors shall be complete with an acrylic floor sealer. Installer to consult with the Caretaking Department on brand of sealer and method of application prior to installation.

All washroom floors shall be homogenous tile or vinyl flooring, unless otherwise approved by the University. Sheet goods are to have a continuous 'wrap-up' return cove at least 100mm up wall surfaces and sealed watertight around all piping penetrations. In washrooms, use porcelain or ceramic tile around urinals and high velocity hand dryers. Ceramic tile on the floor shall be non-skid with epoxy grout.

Use metal edge strips where flooring meets dissimilar materials. A tapered transition strip is to be used where flooring 3mm thick or less terminates on a flat concrete surface without finish. Terminate all floor finishes at centreline of door.

Where practical, specify non-slip material surfaces at entry vestibules, stair and ramp landings.

Housekeeping pads for mechanical equipment are to be painted grey with edges painted yellow along the perimeter edge and on top of the pad 75mm in from the edge.

All floor penetrations are to be sealed so that no water can penetrate to the floor below. Floor access panels to be waterproof and have a recess to accommodate finish flooring material to a flush plane. Due to limited lifespan, parquet and laminated wood floor materials are prohibited. Installing floor finishes across building expansion joints is **strictly** prohibited.

Carpeting is preferred in all secondary corridors, classrooms and offices, unless otherwise specified. Classroom & corridor carpeting shall be no less than 28oz. broadloom or carpet tile with woven nylon and a 20-year warranty minimum. Office carpeting shall be no less than 26oz. broadloom or carpet tile with woven nylon and a 20-year warranty minimum.

Carpet construction shall meet the following minimum requirements:

- Yarn of 100% first quality, type 6/6 or 6 bulk continuous filament (BCF) nylon.
- Solution dyed or other method providing permanent stain resistance inherent in or bonded to nylon fibre.
- Construction shall be level loop or textured level loop and carpet face must be 100% recyclable.
- Plies shall be a minimum of three (3) and pile height shall be between 4-5mm maximum.
- Tuft Bind shall be a minimum 12lbs wet or dry.
- Minimum Stain Resistance (STR) level of 8" high traffic areas and 6" low traffic areas based on accepted test at 5 washings.
- Permanent anti-static filament with static generation below 3.0kV.
- Flame spread rating and Smoke Development Class to meet CAN/ULC standards.
-
- Presently accepted products currently in use include Armstrong (Royal) or Johnsonite Tarket (Granite) vinyl sheet goods and Tandus (Coliseum & Forum) and Lee's (Faculty Classic) carpet and carpet tile.

5.4.5.2 Ceramic Tile

Practices

Floor tile for wet areas, stairs, and ramps shall have a non-slip finish, except under food service equipment. Use smooth finish under kitchen equipment.

Conventional reinforced Portland cement mortar setting bed placed to a thickness of 25 – 30mm over a waterproof membrane is required in wet areas. Use thin set mortars in accordance with manufacturer's recommendations for floors. Use thin set mortars when tile is installed over cementitious materials. Specify subsurface preparation for all projects.

Setting bed over a wood subsurface shall be a minimum 30lbs asphaltic felt, anchored galvanized lath, with a minimum 25mm Portland cement mortar bed.

Liquid-applied or towelled-on-type waterproof membranes are prohibited. Waterproof membrane shall be sheet-type, turned up six inches at walls to form a "pan".

Control joints shall be made at all sub-floor control joints. If no sub-floor control joints exist, control joints must be 3:1 - 4:5m in all directions depending on room size and tile layout. If columns are present, control joints should run between each column.

Select floor grout colours in dark colour ranges to reduce discoloration and unclean appearance. Stain resistant or acid resistant grout materials shall be used for tile surfaces subject to heavy use or chemical exposure. Use epoxy grout in wet areas.

5.4.5.3 Wood Flooring

Practices

Due to limited lifespan, parquet and laminated wood floor materials are prohibited. Wood flooring shall be hardwood, kiln dried to a maximum moisture content of eight percent. Wood flooring installed over a concrete slab shall be applied over a vapour barrier membrane.

Expansion voids shall be provided at walls and other permanent obstruction. Dimension of expansion void shall be not less than recommended by the flooring manufacturer.

Resilient wood flooring, such as engineered flooring assemblies intended for use as: wood aerobic flooring, wood gymnasium flooring, wood handball courts, or other wood athletic flooring; shall be design engineered specific to the intended use.

5.4.5.4 Resilient Flooring and Wall Base

Practices

Resilient flooring is to be of sheet vinyl or linoleum, except in kitchens and animal rooms, which shall be composed of seamless epoxy. Minimum thickness of resilient flooring is 3mm. Resilient flooring shall not be used in toilet rooms, wet areas, or areas exposed to grease or chemical spillage.

Install resilient flooring prior to the installation of cabinetwork and base work. Sheet floor covering shall be installed with water-based, low VOC adhesives as per manufacturer's instructions.

Vinyl wall base is not allowed. Base shall be rubber, minimum 100mm high, with integral cove. Light coloured base, susceptible to visible scuffs and soils, are prohibited.

Kitchens shall be quarry or epoxy smooth seamless, non-porous flooring or ceramic tiling.

5.4.6 Ceilings

Practices

Avoid spray-applied acoustical finishes and treatments.

Use of fire-rated acoustic ceiling tile systems and concealed spline support systems are prohibited.

Acoustic material shall be non-combustible.

Select appropriate materials for areas of high humidity. Support systems in high humidity areas shall be of non-corrosive materials.

For remodeling projects, assuming availability, product shall be specified to match existing appearance. Do not obscure existing windows and doors by bulkheads or ceiling wells of lesser height. Changes to finished ceiling

heights in existing spaces must not create new limitations for door and window operation or inhibit light transmittance. Proper bulkhead transitions should be used at plane changes and to establish clearances at window wells, when required. Renovation solutions where ceiling heights impact existing areas are to be reviewed by the Project Manager before implementation.

For Acoustical Ceiling Treatment (ACT) systems, the following requirements apply:

- No gaps for ventilation are permitted in the T-bar grid system. Ventilation must be obtained separately.
- Main T's to be 15/16" x 1½" supported by wire hangers at 4' o/c.
- Cross T's to be 5/16" x 1" intermediate cross T's. Wire hangers onto main T's shall be #12 galvanized steel wire.
- Wall moulding to be mechanically fastened 1" channel or angle shape with 1" channel or angle shape with 1" exposed face.
- All T-members in exposed grid systems are to be positive interlocking type.
- Finish shall be low sheen satin white unless otherwise specified.
- Lighting fixtures not to be supported by intermediate cross T's. Fixtures to be mounted on main T's or 1½" cross T's.
- Ceiling tiles are to be 610mm x 1220mm, with a minimum acoustic coefficient and a washable surface.
- Vestibules with ACT systems require locking clips and egg crate panels due to high wind gusts.

5.4.7 Lighting

Practices

The University recommends the illuminance categories established by the Illuminating Engineering Society of North America (IESNA) which describe standards based on the amount of light required for a task or activity.

Lighting decisions in the design stage often reflect initial cost constraints rather than lighting needs or performance and become short-term solutions for long-term issues. Periodic scheduled maintenance is necessary to maintain optimum performance of all fixtures and cannot wait for crisis management. This means that lighting decisions must include qualitative and functional merit as well as initial and continuing costs when assessing value.

Lighting facilitates safe, secure passage through the campus at night and enhances and unifies the appearance of campus buildings at all times. Planning for campus illumination should address issues of personal safety, aesthetics, and energy efficiency. Illumination of interior and exterior spaces are to be appropriate in terms of fixture types for specific locations and uses, foot candle levels and uniformity ratios. Lighting should be at a perceived "safe and secure" level along designated pedestrian ways and not cause light pollution.

Lighting fixtures are to be accessible for routine maintenance (lamp changes and cleaning, as necessary).

5.4.8 Interior Doors

Practices

Frame assemblies for interior door installations are to consist of pressed steel frames (16 gauge) fabricated to Canadian Steel Door and Frame Manufacturers Association (CSDFMA) specifications or welded steel frames. Glazing to provide for security/visibility within suites or offices should be incorporated within the door leaf or sidelights.

Interior anodized aluminum storefront framing to be non-thermally broken type with a capacity for single glazed dry unit installations.

In areas of high humidity (i.e. swimming pools) thermally broken double glazed aluminum framing should be used.

University standard interior doors are solid core with birch veneer. Existing doors that are non-code compliant should be reviewed with the code authority prior to reuse. Door hardware requiring either tools or special knowledge to open in an emergency should be replaced.

5.4.9 *Acoustic Requirements*

Intent

The intent of establishing acoustic guidelines is to ensure that various work, studio and instructional environments are conducive to learning and productivity and are compatible with the requirements and comfort of students, staff and faculty.

5.4.9.1 *General Requirements*

Practices

Utilize good planning, economy and functional criteria in consideration of the design of wall systems in accordance with established Sound Transmission Classifications (STC) to mitigate airborne and direct sound transmission. More specialized spaces should have an acoustical or theatre consultant as key members of the design team.

5.4.9.2 *Instructional Spaces*

Practices

All instructional spaces should be designed for the attainment of high speech intelligibility and isolation of general presentation noise to adjacent spaces.

Do not locate instructional spaces adjacent to areas that generate excessive sound such as mechanical rooms, large or public open staircases, galleries, washrooms, assembly areas, gymnasiums or music rooms.

It should be assumed that all classrooms will eventually, if not regularly, be used for the showing of film/video, and that the auditory noise should be contained. Therefore, acoustic design and materials should always be incorporated in classroom construction. An acoustical consultant should be consulted on larger or uniquely shaped instruction rooms.

In larger group lecture rooms or multi-media classrooms a stepped ceiling, which disperses sound may enhance the acoustical setting. Avoid curved walls and ceilings, however, which may focus sound or cause unexpected echoes. (In addition, care should be taken to assure that projection lines and viewing or sightlines are not obstructed by stepped ceilings.)

Do not locate doors in common walls between classrooms. Where this function is absolutely necessary, consider double doors or a sound-lock vestibule with full perimeter acoustic seals.

Isolation strategies, internal wall baffles, and/or acoustic treatment of ceilings and walls should be considered for larger capacity rooms. In larger classrooms, wireless microphones are required where voice reinforcement is necessary, so that the lecturer's movements are not inhibited or impeded by microphone cables.

Isolate, as far as practical, through the use of full height walls that terminate at the underside of metal decking. Provide a complete air seal at metal deck, piping, ductwork and conduit junctions and penetrations.

Use of operable partitions will generally not provide sufficient sound isolation for adjacent classrooms to function without interruption and should be avoided. If operable walls must be provided, products with STC 50 or better must be used.

5.4.9.3 Offices

Practices

Where speech privacy is important, walls should be constructed as full height insulated wall systems and continuously sealed to structure at floor, side wall, wall penetrations, and ceiling perimeter. Where this is not possible, consider using High-CAC (Ceiling Attenuation Class) ceiling systems which have a CAC greater than 35 and provide excellent sound blocking characteristics.

Where speech privacy is required, interior windows require a STC similar to the walls. This will typically require double-glazing with sealed units and/or air spaces that are larger than normal. Sound sweeps and perimeter gaskets for office doors should be considered on a case by case basis.

5.4.9.4 Common Areas

Practices

Locate student gathering spaces away from instructional areas and close to other noise-generating activities such as open stairwells, major building centres.

Partitions surrounding common areas are to be constructed to the requirements of the appropriate STC rating in consideration of activities in adjacent areas as full height insulated wall systems.

5.4.9.5 Gymnasium

Practices

Consider use of acoustic roof deck and/or impact resistant acoustic panels. Adhered ceiling tiles to substrates are not permitted.

Consider use of additional sound absorptive material to upper portion of sidewalls. Treatment should have a minimum NRC 0.70.

An acoustical consultant should be involved on projects for large gymnasiums.

5.4.9.6 Washrooms

Practices

Provide a double plumbing wall between washrooms and instruction space. Ensure structural separation is maintained and piping is attached ONLY to washroom side of the double wall.

Where there are no washroom doors, provide sound absorption materials to walls (minimum NRC 0.85) and indirect view lines at entry.

5.4.9.7 Music Practice Rooms

Practices

One- or two-person practice rooms should have a sound absorptive finish with a minimum NRC 0.80 on all wall surfaces in order to minimize room resonance. Doors should have double glazing, perimeter gaskets and sound sweeps.

Larger group practice rooms will benefit from adjustable acoustics providing a more live setting. An acoustical consultant should provide recommendations on shape, partition assemblies and overall acoustical treatments. Provide steel or solid core doors with full perimeter seals and avoid mechanical ducting that promotes “cross-talk” between practice rooms. Provide sound sweeps on doors.

5.4.9.8 Mechanical Acoustic Considerations

Practices

Consider the impact of mechanical noise on nearby residences or other noise-sensitive areas or properties.

In general, locate the mechanical room or main air handling equipment away from noise sensitive areas such as instructional spaces. Ensure large equipment is equipped with vibration isolation hardware appropriate to its location.

Strategically locate outdoor mechanical equipment or intake/exhaust openings to diminish noise pollution and impacts on surrounding public areas. For remote facilities, in the absence of a noise by-law, design systems to a maximum noise level of 55dB(A) at the facility property line.

Locate rooftop equipment over corridors or other non-critical areas; avoid locating duct shafts or placing equipment over instructional or other learning spaces. Whenever possible, design the system layout so that any medium velocity ducts and terminal boxes are in non-instructional areas. Avoid excessive roof penetrations.

Where classroom doors are located immediately adjacent (along a corridor) or directly opposite (across a corridor), keep ceiling-mounted return-air grilles within the rooms as far apart as feasible or, in the case of a series of classrooms or offices, evenly spaced from one another. Return air grilles need not be directly above the room entry. Where a wall partition between an instructional space or office and a corridor continues above the ceiling to the roof-deck, openings in the wall above the ceiling for return-air need not be directly adjacent to the return-air grille in the classroom/office ceiling. Even distribution of openings along the corridor is recommended. For particularly noise-sensitive areas, consider a sound trap duct (Z- or L-shaped) with no line-of-sight visible through the sound-trap.

For an air-handling unit that draws intake air from the room it is contained within, allow sufficient clearance between the air-intake and the facing wall. The clearance should not be less than the maximum dimension of the intake grill.

Locate an in-duct silencer within the mechanical room as close as possible to the wall that the duct penetrates. For walls that are not fire rated, part of the silencer should penetrate the wall.

Use flexible connections between fans, plenums and all related ductworks.

Maintain adequate spacing between duct wall and the nearest wall(s) with a clear dimension of at least 150mm. Use masonry construction for large mechanical shaft walls that are common to occupied areas.

Provide smooth airflow conditions near the fan units to minimize air turbulence. Large, rectangular ductwork with medium and high air velocities can create low frequency duct rumble. Spiral-wound, round ducting is preferred for air velocities over 9m/s or where excessive turbulence is anticipated.

Select terminal box on basis of both in-duct and radiated noise level and ensure that design conditions correspond with these requirements. Suspend terminal box and other similar equipment independently from deck above without resting on ceiling system.

Plan separate supply feeder duct into each room from main supply trunk over corridor. Do not provide one common trunk-duct directly above rooms with short take-off(s) into each room. Select diffusers/air outlets so that the combined sound from all diffusion in a room meets the design criterion. Provide at least 600mm of straight duct ahead of diffuser inlet.

Locate balancing damper at least 2m upstream of diffuser/outlet.

For renovation of spaces using perimeter heating cabinets equipped with air-induction coils, induction unit **MUST** be moved/relocated if situated where a new wall is to come. Continue wall/partition in through cabinet with airtight seal around piping.

Locate furnaces outside of lecture rooms or in suitable closets to ensure background noise level criteria are maintained. Provide adequate silencing of supply and return air from furnaces. Utilize acoustically lined plenum ducting or transfer ducts as applicable.

The use of heat pumps should only be considered where all other options have been reviewed as non-viable. Locate units outside instructional spaces.

Do not use in-wall ventilation in lecture rooms unless the equipment has certified noise data indicating that the background noise criteria can be achieved at a distance of 1 metre from the unit.

5.4.9.9 Plumbing Noise

Practices

Use a resilient sleeve around supply pipes, with oversized clamps fastened to structure, in areas where water flow noise may be a disturbance. Sleeves comprised of 12mm thick closed-cell elastomeric pipe insulation or proprietary resilient pipe fasteners are acceptable. Do not use hard plastic sleeves.

Clamps supporting risers should be separated from the floor with vibration isolators and should be oversized to accommodate a full surround isolating layer between pipe-wall and clamp.

Where perimeter radiant wall fin cabinets are planned, ensure the use of non-continuous cabinets that terminate at intersecting walls. Discontinue use of fins at all wall junctions and provide for a complete airtight seal where the heating pipe passes through the wall.

Ensure that pipes penetrating through drywall partitions are not rigidly connected to the structure. Provide a sleeve at the wall opening, leaving an air space around the pipe, and seal with resilient caulking. Where double plumbing walls are used (e.g. washrooms), attach supply piping only to the fixture side of the wall structure.

Consider the use of pressure reducing valves (PRV's) in the system to minimize plumbing noise for sound sensitive areas. Size PRV's to limit the pressure at fixtures to 375kPa.

Divide water supply lines at the riser with each room fed separately. Tee takeoffs serving back-to-back fixtures in separate washrooms should be avoided.

Install water hammer arrester adjacent to any quick-acting solenoid valves.

5.4.10 [Reserved]

5.5 Conveyance Systems

Intent

Provide safe movement of occupants in a defined building circulation and wayfinding system with sufficient capacity, visual interest and access.

5.5.1 Interior Stairs

Practices

Design criteria to be incorporated into interior stair configurations include the following:

- Provide clear sight lines throughout the stair enclosure to minimize concealed or alcove configurations.
- Install durable surfaces and finishes to address high pedestrian traffic volumes in stairs designed for primary vertical circulation and exiting.
- Provide appropriate illumination levels to ensure visibility in the horizontal and vertical dimension.
- Incorporate window lites into access doors to ensure clear line of sight in direction of travel.
- Select floor materials that incorporate a non-slip finish with a visually distinct contrasting material colour, pattern or texture signalling a change in vertical dimension (landings and required nosings). The solution of specifically implementing a painted yellow non-slip line for this purpose is to be avoided.
- Consider the use of stair circulation at a higher level of impact than defined by code, allowing for increased stair width to reflect this preferred mode of travel by students.

The two types of approved stair assemblies for interior circulation and exit stairs are as follows:

- Cast-in-place concrete stairs inclusive of intermediate landings between floors;
- Metal stair configurations consisting of stringer and metal pan assembly configurations inclusive of concrete topping installations. Floor and intermediate landings may be incorporated into the structural building framework or be designed as a composite construction assembly to conventional steel stair components.
- Wood stairs, except in building of low-rise residential construction, are prohibited.

Interior finish applications to interior stair enclosures are to incorporate the following guidelines:

- Wall finishes are to incorporate durable high impact finishes applicable to the intended volume of pedestrian circulation (circulation stair) or use as a vertical service corridor. Substrates supporting these levels of finish are to be impact resistant (cast-in-place concrete or masonry wall construction).
- Ceiling finishes to exit stairs and vertical circulation are to consist of similar finishes to interior walls with properties of durability and impact resistance.
- High level architectural wall and ceiling finishes on stair interior should be limited to feature elements and at the main entry level servicing the public and building occupants on a regular basis. Applied finishes in these locations should also be considered as durable and impact resistant to acceptable measures that do not compromise design intention.
- Floor finishes are to incorporate impact resistant durable non-slip finishes with colour or pattern contrast at changes in vertical elevation consistent with Canadian National Institute for the Blind (CNIB) definitions for minimum visual contrast for the vision impaired.
- Incorporation of non-slip grip surfaces at vertical transitions (carborundum composite strips) should be considered adjacent to primary entry points to facilities where slip resistant requirements are identified.
- Paint finish applications to stair accessories (guardrails, handrails and balusters) should be minimized within circulation/exit stairs or service stair configurations to minimize maintenance.

- In general, architectural finishes and treatments to stair accessories within public circulation or prime entry feature stairs should be consistent with the level and type of architectural finishes or treatments found elsewhere in that building and on campus.

5.5.2 *Conveyance and Exit Stairs*

5.5.3 *Passenger Elevators*

Practices

All equipment installed shall conform to the latest edition of the CSA B44 Safety Code for Elevators, the Alberta Building Code and the requirements of the Alberta Safety Codes Act and Elevator Regulations.

Upon completion of a project, a full complement of submissions including manuals, wiring diagrams and As built shall be provided to the University for the equipment.

Install elevators in buildings which are two stories and higher. The building design shall provide direct service to all floors in the building including floors where mechanical rooms are located.

The decision as to the type of elevator equipment provided must be arrived at by means of a thorough load analysis and traffic study. This study and all the information used to generate it must be reviewed by the University of Lethbridge (Facilities) elevator coordinator before approval of the type(s) and quantity of elevator that will be used for a particular application. Proposals for elevator equipment operating at or near their maximum limit is not acceptable.

Elevators should be located centrally in the building or where the walking distance to any point on the floor plate does not exceed a maximum of 45m. Where the location of the elevator(s) exceeds 45m from any point in the building then separate elevator service should be provided in distributed segments of the building where the walking distance from any point in the building to the elevator(s) does not exceed 45m.

The number of elevators provided for any building shall be determined by the specialist elevator consultant via a theoretical elevating traffic analysis based on recognized elevating principles and the expected use, population and occupancy for the building.

Lifts for persons with disabilities, barrier-free Reno lifts or wheelchair platform lifts shall not be acceptable as passenger elevators.

5.5.4 *Freight and Service Elevators*

Practices

Freight elevators should be located adjacent to service entrances, service corridors and loading docks as applicable.

For light use applications with 4 stops or less and a maximum rise of 14m, the use of hydraulic equipment shall be acceptable. Heavier use applications or when the number of stops and rise exceeds 4m and 14m respectively, then traction elevator equipment shall be used.

Service elevator cabins should be large enough to accommodate a 2,450mm table cart (not including clearances) and have a clear cab height of not less than 3,050mm beneath the exposed ceiling.

Vertical sliding or bi-parting doors shall only be used on true freight elevators where no passenger use is required and where a maximum of opening width is required. Vertical sliding or bi-parting doors exceeding 2,450mm in width shall be power operated. Vertical sliding or bi-parting doors 2,450mm or less in width may be manually

operated unless specific site or building requirements require power operation. The need for power operated doors shall be determined by the design team in consultation with the Project Manager at early stages of any project involving freight elevators.

Freight Doors are to be vertically bi-parting doors with 1½ hour fire rating.

5.5.5 *Elevator Finishes and Fixtures*

Practices

Please refer to the Appendix for Elevator Finishes and Fixture Schedule

5.5.6 *Elevator Mechanics and Operation*

Practices

For hydraulic elevators, dual jack, and hole-less hydraulic elevators are preferred for two stop applications to eliminate the need for a cylinder hole and buried hydraulic cylinders. For applications with 3 or more stops generally provide single piston direct acting hydraulic elevators unless soil or other considerations preclude drilling of a suitable cylinder well hole.

Machine rooms for hydraulic elevators shall be located adjacent to the hoist way at the lowest landing. If necessary, elevator machine rooms may be located remotely within 20m of the elevator hoist way upon approval of the Project Manager.

For electric geared or gearless traction elevators, machines shall be mounted on a structural machine room floor slab designed to support the reactions from the equipment without the need for machine beams. Provide a detailed layout and/or template for the machine room floor slab prior to construction with precise locations for the passage of ropes, conduit and other components. Openings in the machine room floor shall be kept to a minimum and shall be limited to the passage of ropes and electrical wiring and conduit.

For electric geared or gearless traction elevators, the machine room shall be located directly overhead unless height restrictions preclude a rooftop machine room. In which case, geared machines may be located at some other floor, generally at the lowest landing, adjacent to the hoist-way.

Where two or more elevators are operating in a group, the operation shall be a group supervisory system, providing automatic collective control for each elevator and a group dispatching and hall call allocation system. A hoist-way access keyed switch and operation shall be provided for each elevator for access to the elevator car top regardless of the floor-to-floor height, car speed or other parameters.

5.5.7 *Maintenance of Elevators*

Practices

For a period of one (1) year from certified date of substantial performance of the project, the complete maintenance of the elevators will be the responsibility of the Elevator Installation Contractor. During this one-year period, the Elevator Installation Contractor will carry out the following duties in addition to the requirements of the complete maintenance program:

Once a month:

- Report to the University's representative to determine if any problems have occurred which were not subject to a call back and address any noted issues immediately.

- Perform a check for general operation of the elevator including quality of ride, door operation and levelling. Observe the correct operation of all elevator button operations and door detector. From the cab, observe the door dwell times and open and close timing.
- Check the general noise level of ride and operation and take immediate corrective measures where performance is not acceptable.
- Check and replace lamps and failed components as necessary.

Every two (2) months:

- Check all safety circuits and door interlocks for general operation and adjustment.
- Check governor tension sheave and lubricate.
- Observe all roller guides and the limit and over-travel switches in actual running conditions.
- Review the overall flight time of the elevator.

This maintenance shall be scheduled during regular trade work hours of the University and include regular inspection, adjustment, and lubrication, call back for faulty operation, and the replacement of all parts and components which fail for any reason other than through malicious damage or gross misuse of the equipment. This shall include parts replaced as part of warranty as well as parts to be replaced due to normal wear and tear. Work shall be performed by competent personnel under supervision and in direct employ of the elevator manufacturer or licensed agent. The installer shall maintain a stock of parts in the equipment room and local warehouse adequate for repair and replacement.

As part of the maintenance service contract, the contractor shall be responsible to service and maintain, and operate all elevator emergency circuits including the emergency recall and emergency power features in regular University scheduled testing.

The Elevator Installation Contractor is to obtain and pay for certificates of approval and all other necessary permits, inspections and re-inspections, if necessary, due to any failure of any elevator equipment.

The Elevator Installation Contractor is to pay all patent licensing fees and royalties necessary for the completion of the contract and the University will not be held responsible for infringements of patents of the elevator subcontractor in the completion of his contract.

Only non-proprietary elevator equipment is to be installed so elevator equipment can be maintained by any competent licensed maintenance provider.

Contracts are to include 24-hour callback service due to equipment related problems at no additional cost to the University. Call back response time is not to exceed 60 minutes. Call-backs determined to be caused by acts of vandalism shall be an extra to the contract.

At least 30 days prior to expiration of the warranty maintenance period, the contractor shall schedule a final inspection with Facility Operations and Maintenance. All deficiencies noted shall be corrected prior to expiration of the warranty maintenance period at no cost to the University.

Minimum requirements for elevator warranties include:

A written guarantee signed and issued in the name of the University stating that all materials and workmanship of the apparatus furnished under the specifications is guaranteed for one (1) year from the date that the University has exclusive use of the elevator. This warranty shall be in lieu of any other warranty expressed or implied and shall include coverage for, but not be limited to the following:

- Blistering or peeling of paint due to improper surface preparation of materials.
- Opening of joints due to improper design or ineffective fastening methods/devices.

- Repairs, replacement or equipment part failure made necessary by reason of negligence, misuse, accident or improper or inadequate maintenance on the part of the Elevator Installation Contractor.

In the event of an emergency failure of any components, materials or systems during the warranty period – and the issuer of warranty is unable or chooses not to respond for immediate emergency repair – the University of Lethbridge may recover from the issuer of the warranty all costs incurred by the University for the immediate repair/replacement required.

5.6 Mechanical/Plumbing Systems

5.6.1 General Requirements

Practices

Common work results for heating, ventilation and air conditioning (HVAC) for outdoor conditions and ambient design information shall be as per Lethbridge region design conditions in the Alberta Building Code. Indoor design conditions for various space types and uses are defined in Table 23 06 00-1 in the Appendix which specify min/max occupancy temperatures where the maximum defined temperature is for the summer (cooling) season and the minimum for winter (heating) conditions.

All University spaces are to be designed according to ASHRAE Standard 62.1-2013, Ventilation for Acceptable Indoor Air Quality or Table 23 06 00-1 – whichever is more stringent.

The University has a standard for tagging of equipment which can be obtained from the Utilities Department.

5.6.2 Mechanical/Plumbing Drawing Requirements

Practices

All drawings must include a schedule of all fixtures and equipment (including chiller, pump, VAV, RHC, etc. schedules). These schedules should itemize the parameters for balancing and the location of service areas or zones.

Dashed lines for equipment on drawings should be indicative of the required space area necessary for access and maintenance (i.e., coil pulls, motor access, etc.).

At the discretion of the Project Manager, the Utilities Department may be engaged at appropriate points in the project as indicated below:

- Initial project design and preliminary budgeting.
- Participate in design and site meetings.

At the discretion of the Project Manager, project sign off by the Utilities Department is to occur at the following project stages.

- Specification preparation.
- 60% & 90% stage construction drawings.
- Change orders.
- Completion.

5.6.3 Laboratories

Practices

All laboratories in design, construction and intended function must conform to all regulatory safety requirements. The Universities Environment, Health and Safety Management System (EHSMS) provides guidance to foster a safe and healthy environment within our laboratory use.

5.6.4 Air Handling and Distribution

Practices

All air handling units (AHU) shall be designed in accordance with applicable standards utilizing free cooling with variable air volume (VAV) systems and variable frequency drive (VFD) zone static pressure control using integrated digital controls and carbon monoxide monitoring. Standard design of air handling units is based on 2.0m/s (400fpm) face velocity using all methods of heat recovery for high performance and efficiency.

AHUs shall be designed integrally with mechanical rooms as indoor units within the building. Roof top units are highly discouraged and require approval by the University. Indoor AHUs are to be located on housekeeping pads with vibration isolation for fans and motors.

AHUs should be tied into the central chilled water and hot water systems of the building, whenever possible. Provide double wall casing for all AHUs. Interior wall perforated liners may be provided in fan sections only.

All ductwork shall perform to Sheet Metal & Air Conditioning National Association ([SMACNA](#)) standards and be pressure tested for leak testing ductwork.

Air handling units shall be located in a manner that provides adequate space for serviceability. Avoid the use of mechanical rooms as air plenum spaces. AHU plenums are to be provided with hinged, sealed access doors to make all sections/chambers accessible for servicing. Provide inspection windows in all fan sections and two lights in each fan and filter module. Marine lights for inspection purposes shall be located in all sections. Lights should be wired to a single circuit switch positioned on the outside of the AHU. Include one (1) 115V receptacle on the outside wall of the middle section of the AHU.

Spare parts required at the completion of construction includes:

- two (2) spare belts for each fan installed.
- one (1) spare seal for each pump installed.
- one (1) set of bag filters for each AHU.
- four (4) sets of pre-filters for each AHU; and
- one (1) complete gasket set for each heat exchanger installed.

5.6.5 Heat Generation/Distribution

Practices

Central heating occurs at the main plant via hot water boilers located within University Hall which is then distributed to most buildings across campus. Preference should be given to a two-pipe reverse return system for heating water piping. A two-pipe direct return system may only be used if the system design properly guards against flow imbalances to the terminal units and it is a small part of a reverse return system.

Consider the following:

- Primary and secondary pumping only where it will reduce power consumption and provide better control.
- Mounting all pumps greater than 3 horsepower at floor level on housekeeping pads (with no racking or stacking of pumps).

- Design all heating piping layouts to avoid being installed over or adjacent to electrical panels, server rooms or other equipment that would sustain damage in the event of a leak.
- Providing isolation, balancing and flow measuring devices at major circuits and equipment. Isolation valves should be installed on supply and return mains, risers, branch lines from mains and equipment connections.
- Providing unions on all low-pressure hydronic system safety valves, located on the atmospheric discharge lines at the closet point to the safety valve for the purposes of removing the safety valve easily during maintenance purposes.
- Providing side stream filters of proper size and orientation that are common to both pumps.

Ensure heating terminal units are easily accessible for inspection, cleaning and disinfection.

All ductworks shall be fabricated from galvanized or stainless steel depending on application. Use corrosion resistant materials for exhaust ducts conveying corrosive fumes and vapours, or where condensation is likely to occur. Flexible duct may be used for low pressure ductwork in runs that do not exceed 900mm (3 feet) or as straight drops to diffusers.

Ensure that good air distribution and occupant comfort are considered through appropriate air supply and outlet application, selection and location.

Provide adequate access for internal inspection and cleaning of all ductworks. Access through diffusers, grilles or duct mounted access doors are to be provided at a minimum of 4m intervals and at every floor in the case of risers.

Provide bull-head tee connection for all ceiling diffusers. Minimum duct size for fire dampers are to be 150mm. Provide locking nuts on all balancing dampers.

5.6.6 Water Supply and Treatment

Practices

Domestic potable water is treated and supplied by the City of Lethbridge. The University does not treat or filter water with the exception of a small number of reverse osmosis units or water softener applications for laboratory spaces. Facilities has experimented with chemical free water applications for cooling towers with inconclusive outcomes versus chemically treated water.

5.6.7 Heat Exchangers

Practices

Heat recovery equipment shall operate at a minimum of seventy per cent efficiency and be connected to the Building Automation System (BAS). Pre-filters are to be provided in all heat recovery equipment.

5.6.8 Natural Gas Systems

Practices

All-natural gas piping to be in conformance with the latest edition of CAN/CSA B149.1.

5.6.9 Hot & Cold Domestic Water Systems & Fixtures

Practices

Domestic hot water is to have re-circulating piping complete with balancing valves where hot water supply piping exceeds 15m. Branch piping from a manually operated faucet to a circulated main shall not exceed 8m or 3 m for a hands-free faucet. Provide flow measurement valves for each major branch of the domestic hot water recirculation system.

Water and wastewater systems are to be designed and installed without concealment of mechanical compression style joints. All grooved piping systems for use with copper tubing are to be manufactured to copper tube dimensions (i.e., no flaring of tube ends to accommodate alternate sized couplings).

Provide isolation valves in accessible locations on supply and return mains, at the bottom of each riser, branch lines and mains, each washroom group, individual fixtures and non-freeze hose-bibs. Provide additional valves on a recirculating hot water system to prevent total system isolation of piping should leaks or other problems arise.

Provide non-freeze key operated hose bibs at no more than 30.5m spacing at the building perimeter. Coordinate the location of hose bibs required on each building face with Grounds and Utilities.

Fixtures to be utilized are to be of low-flow rates where standard water closets do not exceed 4.8litres per flush (LPF), dual flush water closets 6/4.2LPF and urinals 0.5LPF. Waterless urinals are not permitted. Lavatory faucets are to not exceed a rate of 1.9 litres per minute (LPM) and showers 6.8LPM.

Provide eyewash and/or safety showers in areas where exposure or contact with harmful chemicals may occur.

5.6.10 Building Automation, Controls & Communication

Practices

[reserved for future content]

5.6.11 Air Cleaning/Filtration Devices

Practices

Filter sections are to be designed at 2.5m/s (500fpm) maximum face velocity. For 100% fresh air systems, high outdoor air systems or return air heat recovery systems typically with heat wheels, summer and winter position pre-filters are required before and after the initial preheat coil.

Provide the following types of filters at locations indicated:

- Pre-filter ahead of preheat coil to be Merv 10 – 2” heavy duty red fibreglass pads.
- Pre-filter behind preheat coil to be Merv 10 – high-capacity pleats complete with 15 pleats/lineal foot;
- Pre-filter in return air to be Merv 10 – high-capacity pleats complete with 15 pleats/lineal foot;
- Final filter to be Merv 13, 85% ASHRAE efficiency – 6mm (1/4”) thick fibreglass wool pocket filters.

Standard filter sizes used at the University include:

Pre-filters: Merv 10 – 50mm heavy duty red fibreglass pads standard sizes shall be 300x600x50mm and 600x600x50mm.

Filters are to be held in a common universal holding frame for upstream service with universal clip hardware to secure filters in place. Side access applications should be avoided except for systems with limited access or filter banks less than 1.5m high. Common holding frames should be a minimum of 18 ga galvanized steel and the separate pre-filter frame should be constructed the same but with an additional welded wire support grid with mesh openings not greater than 100mm square. Expanded metal support grids are not acceptable.

Common holding frames on filter banks over 1.5m in height must have additional support structure in the form of 18ga galvanized steel flat stock at 150mm wide sandwiched between every second vertical row of frames at full height to prevent collapse.

5.6.12 *Fuel/Chemical Stores*

Practices

[reserved for future content]

5.6.14 *[Reserved]*

5.7 **Fire Protection**

The University has expended significant resources to sprinkler buildings and to maintain the integrity of existing fire rated separations and protect occupants in early campus buildings. In cases where renovations have compromised rated partition systems, work has been remediated and guidelines for future renovation work have been prepared to execute additional fire protection work as renovations make it feasible and accessible.

All fire separations are to conform to established ULC rated designs and systems using compatible and approved components for fire protection and smoke control installed by qualified trades.

5.7.1 *General*

Practices

All assembly occupancy facilities are to be fully sprinklered for fire suppression according to building/fire codes.

Provide as-built drawings of all new installations of sprinkler systems to the technician in Campus Development for all renovations or new projects.

5.7.2 *Fire-Suppression & Life Safety Systems*

Practices

The design of fire and life safety systems are to be designed in accordance with the Alberta Building and Fire Codes and NFPA 13 in effect at the time of design.

All sprinkler systems are to be wet-pipe systems unless installed in areas of potential cold/freezing which require dry-pipe sprinkler systems. Pre-action type sprinkler systems shall be installed in high voltage and main telecom areas complete with metal pan shielding electrical equipment. Coordinate with the Project Manager to confirm if a pre-action type sprinkler system is required in other special use areas.

Sprinkler body shall be die-cast with a hex-shaped wrench boss integrally cast into the sprinkler body to reduce the risk of damage during installation. Wrenches are to be provided by the sprinkler manufacturer that directly engage the wrench boss.

All fire protection device valves shall be externally resettable, and all internal components should be replaceable without removing the valve from an installed position. All sprinkler heads located in storage or electrical rooms where there is no ceiling finish are to be equipped with metal guards or cages to provide protection against accidental impacts or damage. Escutcheons and guards shall be listed, supplied and approved for compatible use by the manufacturer. Sprinkler heads should be provided in elevator shafts and warranted concealed spaces.

Standpipe and hose systems are to be designed in accordance with NFPA 14 and should be provided on a separate feed coming from the main fire protection header.

Portable fire extinguishers are to be provided in conformance to NFPA 10 and in consultation with the Project Manager.

Diagram 5.7.2-1 Hydrant Construction Schematic

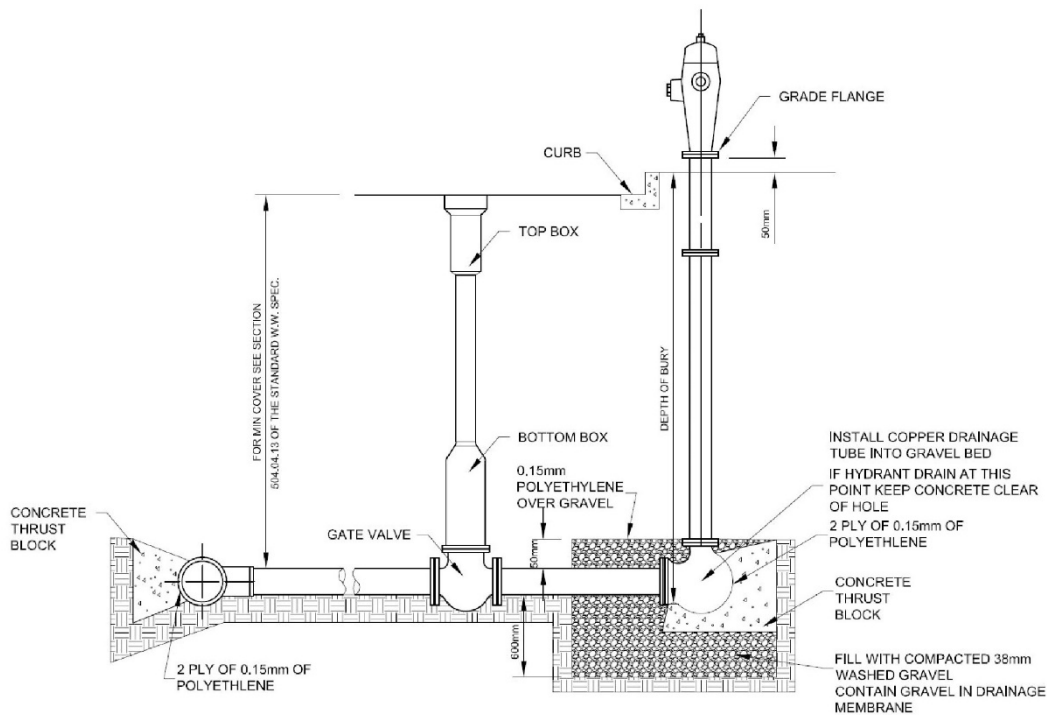

Hydrants in the vicinity of buildings and public areas require (refer to hydrant diagram above):

- The exterior of the hydrant to be coated/painted red.
- Hydrants required to have drains plugged.
- The hydrant shall be placed on concrete pad.
- The end of the ditch at the rear of the hydrant shall be filled with concrete to the level of the top of the pipe and clear of the hydrants drain hole to anchor the hydrant. A pit for drainage 750mm wide 1000mm long 60mm deep shall be dug at the foot of the hydrant and filled with stones, min size 40mm dia. as specified. The space about the barrel and 150mm above the drip hole shall also be filled.
- A .015 polyethylene sheet shall be placed over the top of the stones to prevent the spaces between the stones filling with soil.
- Allow for restraints to be added as directed by Utilities dept.
- Place 2 ply of polyethylene between pipe and poured concrete.
- Concrete shall be sulfate resistant, 20MPa @ 28 days.

5.7.3 [Reserved]

5.8 Electrical Systems

Provide safe and efficient electrical systems that respond to the functional requirements of users and incorporate cost effective energy conservation measure that do not diminish building performance or occupant comfort.

5.8.1 General Requirements

Practices

All electrical design shall be carried out by an Electrical Engineer operating as the Design Consultant. As arranged and coordinated with the Project Manager, the Design Consultant shall meet with the University Electrical Manager to develop and prepare an electrical layout or program for all new buildings and renovations.

Ensure sufficient space and access is provided around and above electrical equipment for safety, ease of maintenance and future component replacement. Allow sufficient space for conduit/cable bending radii and cooling requirements.

Electrical permits are to be obtained by electrical contractors from the City of Lethbridge in advance of work.

Contractor shall verify in writing that he is authorized and approved by the manufacturer of the equipment to make the installation of major components. Co-ordinate and schedule verification for the removal and reinstallation of all devices and components. Schedule work around classes and other events.

At the discretion of the Project Manager, the Electrical Department may be engaged at appropriate points in the project as indicated below:

- Initial project design and preliminary budgeting.
- Participate in design and site meetings.

At the discretion of the Project Manager, project sign off by the Electrical Department is to occur at the following project stages.

- Specification preparation.
- 60% & 90% stage construction drawings.
- Change orders.
- Completion.

5.8.2 Electrical Drawing Requirements

Practices

All electrical work requires as-built drawings. Shop drawings are required for all new equipment, fixtures and devices. Maintenance manuals are to be assembled for related component work for all large projects.

5.8.3 Installation

Practices

Work is to be performed in a neat and orderly manner. Conduit runs are to be installed parallel or perpendicular to building walls or lines. Exposed surface run conduit should be pre-planned to minimize visual impact on surrounding environments for a clean installation.

Multiple materials and components are required to be from the same manufacturer and compliant with CSA or ULC standards.

In addition to the Alberta Building Code, all electrical work, equipment and materials used shall conform to the:

- Canadian Electric Code
- Electrical Protection Act of Alberta
- Canadian Standards Association (CSA)
- Canadian Underwriters Laboratory (ULC)
- Institute of Electrical and Electronics Engineers Lighting Standards
- National Fire Protection Association (NFPA)
- Alberta Occupational Health and Safety Act, Regulation and Code
- University of Lethbridge Design & Construction Standards

The equipment and installation shall also comply with the International Standards Organization (ISO) and local Authority Having Jurisdiction (AHJ).

Smoke, heat and duct detectors are permitted to have a maximum level of 5% “dirtiness” at time of turnover.

5.8.4 *High Voltage Distribution*

5.8.4.1 *General Requirements*

Practices

A Utility Coordination Study is required if/when new switches or buildings are added to the University’s 15kv distribution and emergency power. All switches are to be “dead front” type. Locations of vaults, transformers, meters and other utility items must be coordinated with the architectural design to avoid conflicts with critical architectural features (for example, at main entrances) and must consider both equipment ventilation and removal.

To ensure maximum flexibility for future systems changes, the electrical system must be sized for the demand load with additional spare capacity as follows:

- Panel boards for branch circuits: 50% spare ampacity as well as 25% spare circuit capacity.
- Panel boards serving lighting only: 25% spare ampacity as well as 25% spare circuit capacity.
- Switchboards and distribution panels: 35% spare ampacity as well as 25% spare circuit capacity.
- Main Switchgear: 25% spare ampacity as well as 25% spare circuit capacity.

Prior to adding the spare equipment ampacity to account for future load growth, it is important that the load study reflect actual demand loads rather than connected loads. The designer shall apply realistic demand factors by taking into account various energy conserving devices such as variable frequency drives applied to brake horsepower, energy efficient motors, occupancy sensors, and so forth. The designer shall also avoid adding the load of stand-by motors and shall be careful to distinguish between summer and winter loads by identifying such ‘non-coincidental’ loads. Once the estimate ‘peak demand’ load is established, the factor for load growth should be added.

A method (or system) to drain the manhole is to also be provided.

5.8.5 *Service and Distribution*

5.8.5.1 *Duct Banks*

Practices

Concrete encased duct banks shall be provided with proper cover of at least 1000mm with an excavation warning ribbon installed 300mm above duct bank and shall slope toward manholes. Changes in direction shall be at a radius of 7.5m or greater. Stub-ups from the bank into electrical equipment shall be installed with manufactured elbows and terminate 100mm above the finish elevation of housekeeping pads. Electrical and communication banks shall be kept clear of all other underground utilities, especially high temperature water or steam. Duct line routes will avoid other underground structures in their coordination and planning. When necessary to run communication cables parallel to power cables, two separate systems must be provided with separate access. The same is true for normal and emergency power distribution banks. Duct banks shall be spaced a minimum of 500mm apart and be sized for the number and sizes of cables. Minimum duct sizes for medium voltage services (13.2kV) shall be 155 mm

with a minimum of two (2) spare ducts provided for future expansion. Inner ducts must be provided inside communication ducts when fibre optic lines are used.

5.8.5.2 Manholes

Practices

Manholes shall be spaced no farther than 150 m apart for straight runs. The distance between the service entrance and the first manhole shall not exceed 30 m. Double manholes shall be used where electric power and communication lines follow the same route. Manholes shall have clear interior dimensions of no less than 1800 mm in depth, length and width with an access opening at the top not less than 570 mm in diameter. Manholes must have a minimum wall space of 1800 mm available on all sides where splices are to be racked and shall be provided with pulling eyes, sumps and grounding provisions, as necessary.

5.8.5.3 Main Equipment Rooms

Practices

The main switchgear room is to be securely located in a vault or internal to the building along a perimeter wall at an elevation that minimizes the transformer secondary feeder length. Switchgear room door width and height shall accommodate the removal and replacement of the largest piece of equipment and be equipped with panic hardware.

Main electrical equipment rooms shall be generally located within the core areas of the facility and shall be stacked vertically. An adequate number of electrical rooms serving no more than 930 m² of floor area shall be provided with minimum clear dimensions of 1800 mm by 3000 mm. If transformers are located in the rooms, ventilation must be provided.

5.8.5.4 Electrical Rooms

Practices

Electrical (and mechanical) rooms require a minimum of one emergency power receptacle identified as such at the receptacle.

5.8.6 Emergency Generation Systems

Practices

Existing buildings shall only have loads connected to the emergency power system as required by the University and governing codes.

Equipment in new structures such as fire alarm systems, emergency lighting and security panels shall be provided with emergency backup power. All other equipment will be identified for emergency power on a case by case basis and may include fire pumps, telephone switches, mechanical control systems, Building Automation System (BAS), select elevators, sump pumps, smoke control systems, UPS serving technology or server rooms, exhaust fan or air conditioning in UPS supplied server and communication rooms, laboratory fume hoods and supply fans that maintain building pressurization.

5.8.6.1 Emergency Lighting

Practices

Supplemental battery powered emergency lighting is recommended to be installed to bridge the generator start-up time delay in all generator rooms, main electrical rooms and Automatic Transfer Switch

(ATS) rooms for buildings where ATS is not located in the generator room. Battery packs will not be used in buildings that are supported by an emergency generator except for the areas above.

5.8.7 *Secondary Branch Power Distribution Systems*

5.8.7.1 *Bus Duct*

Practices

Bus ducts for secondary branch power distribution shall be copper, fully rated, 3-phase/4 wire with 100% neutral and an integral ground bus sized at 50% of the phase bus. Calculations are to be provided supporting the specified short circuit rating.

5.8.7.2 *Conductors*

Practices

Distribution conductors shall be RW90, XLPE and minimum #12 AWG for all branch circuits. The base specification shall require copper be utilized throughout including motor and transformer windings, switchgear bussing, switchboard and panel board bussing, bus duct, primary and secondary feeders, branch feeders and branch circuits. Aluminum is not permitted.

5.8.7.3 *Motor Control Centres (MCC)*

Practices

Group Motor Control Centres shall be used where eight (8) or more starters are required in an equipment room. MCC construction shall be NEMA Class I, Type B, copper, with magnetic (or solid state, if appropriate) starters and molded case circuit breakers. Minimum starter size in MCC shall be size 1 and control circuit voltage shall be 120V connected ahead of each starter via a fused control transformer. Control transformer shall be located inside motor starter cubicle. Reduced voltage starters may be used for larger motors to reduce starting kVA.

5.8.7.4 *Variable Frequency Drives (VFD)*

Practices

Variable Frequency Drives (VFD) are not to be mounted in MCC or on high vibration surfaces that can generate and transfer to VFD. Proper vibration isolation must be maintained at all times. VFD shall be mounted at normal working height to allow for maintenance and repair with ladder or movable platform. Integrated drives on pumps shall not be accepted.

Motors for VFD applications shall be for varied operation over the defined speed range and not for continuous operation at a single or limited number of speeds. Motors shall operate continuously at any single speed within the defined speed range. Motors shall be wound using inverter spike resistant magnet wire rated for 3.1 times the rated line-to-line voltage. Shaft grounding brushes shall be used to divert the induced voltage potential between the rotor and stator. Wiring from the secondary of the VFD to the motor is to be 1000 volt rated cable.

Shut-down labelling is to be applied on all drives, disconnects and starters indicating the safe shut-down and maintenance procedures for the VFD(s). Log sheets are also to be supplied and installed beside each to record faults on the drive for trouble-shooting the VFD performance.

5.8.7.5 *Wiring Devices*

Practices

General wiring devices shall be specification grade. Emergency receptacles shall be in red with isolated ground receptacles in orange. The building standard receptacle is duplex, specification grade NEMA 5-15R and housekeeping receptacle be duplex, specification grade NEMA 5-20RA. Housekeeping receptacles shall be located in exterior walls and walls around primary corridors.

5.8.8 *Fire Alarm Detection Systems*

Practices

To be determined in a subsequent Standards revision. See related sections.

5.8.9 *Security Access Systems*

Practices

Contractor to provide a complete rough-in for card access systems as indicated on drawings and specifications. Complete rough-in to include conduit, back boxes, junction boxes, wiring (cabling to end devices) and 120v connections. Coordinate rough-in with all affected sub-trades.

Access control system components, including devices and control components, shall be compatible with the Honeywell security network in place.

5.8.10 *[Reserved]*

5.9 **Information Technology**

5.10 **Furnishings and Equipment**

Intent

Furnishings for convenience, work and public amenity should support campus life and be integrated with the functional and aesthetic design intent of a building or outdoor space.

Quality standard levelers required on seating legs and standard nylon glides required at table bases suitable for tile & concrete finish floor. All furniture to purchases external from Facilities and/or Capital Projects must be procured through a coordinated effort with Building Maintenance, Materials Management, and designated Project Manager or Stakeholder

5.10.1 *Public Furnishings*

Practices

Furnishings intended for use by the public within primary circulation and social areas should provide comfortable, flexible and diverse offering of seating and work surface arrangements that facilitate forms of interaction and private focus. Furnishing selections should be durable and maintainable. Often furnishings of this type are utilized for short periods of time by a large constituent of people. They should be visually interesting when unoccupied and of a quality that is respected by students and staff.

Exterior site furniture and fixtures shall be designed to integrate visually with their outdoor environment and be located for best use, function, comfort and convenience without creating a safety hazard or access issues. Winter conditions should not impede the use of exterior site furniture and fixtures intended for year-round use and materials should be considered for both durability and human comfort or appeal.

5.10.2 *Furnishing Offices and Accessories*

Practices

Building Maintenance will provide a standard list of approved office furnishings and accessories for faculty and staff. Moves and office furnishings and accessories are installed by work order by University personnel.

The University has adopted the Primex Wireless clock system across campus.

5.10.3 *Furniture, Modular/Office Furnishings*

Practices

The University has implemented some modular based flexible partition systems in some departmental areas of the University and graduate student spaces.

5.10.4 *[Reserved]*

5.10.5 *[Reserved]*

5.11 **Services**

5.11.1 *Caretaking Spaces*

Practices

All Caretaking spaces are to be for the sole use of Caretaking and shall not include electrical, telephone, elevator or other control systems unrelated to the room function. These rooms are not to be shared with others for inventory and equipment control reasons.

Caretaking Space finishes shall be durable and easily maintained with a minimum 9' ceiling. These spaces shall be well ventilated, well-lit and well located on corridors close to elevators as well as access points for supplies arriving and trash leaving.

Caretaking break room finishes will include durable, easily maintained sheet vinyl or rubber flooring, durable paint on concrete block or gypsum wall board walls and acoustic ceiling tile with adequate fluorescent lighting. Break rooms will be well ventilated with adequate electrical wiring and data for appliances and computers as required. They shall include enough table space with chairs to accommodate the staff, a secure key cabinet, millwork that includes a sink, upper and lower cupboards, and a counter with at least 450mm of clear linear space and two 1200mm x 1800mm bulletin boards mounted on the walls.

When there are more than four caretakers involved there shall be one change room provided per gender with a minimum area of 3m² each. Change rooms will be adjacent to locker areas and break rooms.

For caretaking storage and supply rooms the following requirements apply:

- Doors shall swing out and be large enough to permit free movement of equipment and cleaning supplies though they must not interfere with exit widths in corridors. For the larger rooms this will mean double doors.
- Ideally there shall be one Caretaking Storage Room on every floor of every building, though on a small building floor plate area it may be combined with a Caretaking Wet Room.
- Caretaking Storage Rooms shall be near loading docks and elevators where possible.
- Minimum size of Storage and Supply Rooms shall be 1.8m x 3m but may be as large as 5.5m x 6.5m. They will be fit with free-standing shelving units.

- Caretaking rooms shall be provided with stand-alone shelving that is no higher than 1.22m and that is bolted to the wall.

Ideally there should be a caretaking wet room on each floor of every building with; an out swinging door, adequate ventilation, one floor-level service sink for water with a curb equipped with hot and cold-water outlets, and a complete chemical dispensing system. Floor drains outside the service sink is also needed. Wet Rooms to be finished with stain/chemical resistant anti-slip flooring material or sealed concrete and have ceramic tile walls immediate to the service sink. Ceiling must be gypsum wall board.

Dry Trash Spaces for Caretaking services should be located off the loading dock, accessed from the corridor. They will vary in size based on size of facility and recycling protocols and shall have an out-swinging door.

5.11.2 Maintenance Storage

Practices

Dedicated storage and shop areas for the purposes of the Building Maintenance department are to be discussed during planning and functional programming stages of a project in order to ascertain specific needs.

5.11.3 Loading Areas

Practices

Provide dedicated service entrance (loading area) at the rear of building. Service entrance to be accessible from the service drive and located adjacent to the waste disposal, maintenance and holding rooms.

Access to building should suit purpose of loading requirements for expected equipment. As a minimum, access doors are to be via double set of 1200mm wide doors or insulated overhead door at a minimum 2440mm wide by 2750mm high. (Where an overhead door is provided, provide a separate main door.) Door quantities to be determined by building size and planning requirements.

Provide a 1800mm deep loading apron between access doors and face of loading dock where double doors are used. Apron to have wall protection to minimum 1200mm above apron floor. Apron not required at overhead doors. At loading dock, recess truck bay to accommodate flat bed of truck. Provide a dock leveller with a 2300kg capacity to allow roll-off from truck bed.

Provide 200mm diameter steel concrete filled pipe bollards adjacent to loading area to protect building.

Provide a full width room off access/loading doors a minimum 3.1m deep. Provide double doors to building circulation and wall protection to 1200mm above finish floor as required to protect building components.

5.11.4 Recycling and Waste

5.11.4.1 Recycling

Practices

The University of Lethbridge has been a leader in Southern Alberta for materials recycling with an organized paper and cardboard recycling program in Lethbridge. The University also collects other recyclables to supplement student initiatives such as plastics and aluminum.

Recycling spaces should be considered during planning and functional programming stages of the project. They should not intrude on public space but be accessible and available in public areas by means of alcoves in secondary hallways or discreet containers that complement their environment.

For detailed information on University recycling programs, consult with the Facilities Caretaking Manager.

5.11.4.2 *Refuse Removal*

Practices

Verify with Facility Management the requirements for waste collection and the method of disposal, compaction and holding. Requirements will vary depending on program needs and size of building.

Where volume of waste warrants, a stationary compactor will be located adjacent to Service Entrance. For lower volume a dumpster located outside of the building adjacent to the Service Entrance will be used. Space for dumpster to allow loading of dumpster without requirement of manual lifting.

Linen, trash and other recyclables are to be collected in containers and taken to holding rooms located.

5.11.5 *[Reserved]*

5.12 **Special Collection and Demolition**

5.12.1 *Existing Buildings*

Practices

[reserved for future content]

5.12.2 *[Reserved]*

6.0 STANDARDS OF SPACE DESIGN

6.1 Introduction

6.2 Instructional Spaces

6.3 Laboratory Spaces

6.3.1 *Laboratory Fume Hoods*

Practices

Fume hoods are an enclosed chamber fitted with an exhaust ventilation system. Fume hoods perform as a component of an exposure control system designed to contain, dilute and disperse gases, vapours and aerosols to the external environment. Fume hoods also act as an integral part of the building air handling system. In addition to protecting lab occupants, the efficiency of operation of fume hoods is essential in maintaining good air quality in laboratories. The applicable reference fume hood standard is CSA Z316.5-04 (R2014) - Fume Hoods and Associated Exhaust Systems. The fume hood must meet all environmental Certificate of Approval requirements.

The performance of a fume hood in the exposure control system cannot be judged in isolation from the rest of the building air handling system. The total system consists of the working chamber, the exhaust system, fume hood location, make-up air to the hood, system indicators, operational parameters, and system maintenance.

The working chamber should be based on a variable air volume (VAV) system with a non-flammable, acid resistant interior and back baffle system to distribute air more evenly across the face of the chamber so uniform air will flow through the face of the hood. An airfoil along the lower edge and vertical sliding sash with counterweights to minimize the aperture size should be specified. A recessed work surface to retain spilled liquids built of sufficient support to bear the weight of equipment or necessary shielding material should be considered.

The exhaust system ducting shall provide optimum air flows in the working chamber and sized to minimize noise. Ducting should avoid horizontal runs to minimize the accrual of corrosive condensates. Ducting should be labelled with a unique identifier at the fan, exhaust stack and hood itself and be installed with circular cross-section ducting to reduce the number of corners and crevices where corrosion might occur using type 316 stainless steel and welded construction (except where chemicals used require compatible materials throughout).

The exhaust fan shall be located to ensure that the exhaust ducting below the fan within the building remains at negative pressure, except for ductwork on the positive side of the exhaust fan in the mechanical room. The exhaust stack shall be positioned to ensure that emissions are unable to re-entrain into the building or adjacent buildings and that discharge stacks are connected to a properly installed trap and drainage system (not drain into the exhaust fan). Supply air diffusers in the laboratory shall be low-velocity type. Provide make-up air to replace exhausted air and maintain negative pressure in the laboratory.

Air flow through a VAV constant velocity fume hood shall provide an average face velocity of 0.4 m/sec (80 ft/min) - 0.65m/sec (130ft/min) regardless of sash height.

A fume hood must be in such a way as to minimize risks to persons in the event of fire or explosion, and away from interfering room air currents caused by doorways or ventilation components and with sufficient space to maintain room circulation and access to exit.

Fume hoods used for nuclear substances will be identified with the radiation warning sign. Fume hood exhaust ducts must be marked with the radiation warning symbol at 3 metre intervals. The fan and exhaust stack must also be identified with the symbol. If the fume hood is used for storage of nuclear substances, it will remain on at all times. If the fume hood is to be used for continuous exhausting of radioactive substances:

- the exhaust fans will be connected to an emergency power system and
- the fume hood exhaust will not connect to other exhaust systems.

Fume hoods will not contain filters. The exhaust stack shall discharge vertically upwards at a velocity of at least 1.4 times the average wind velocity, and be so positioned as to ensure that emissions are unable to re-enter the building or adjacent buildings; the minimum recommended distance to any air intake is greater than 15m. For new buildings, the stack height will be at least 3.05m above the highest point on any adjacent building, and the stacks will be downwind of any air intakes where possible to determine a prevailing wind direction.

6.4 Office Spaces

Practices

[reserved for future content]

6.5 Meeting, Seminar and Collaboration Spaces

Practices

[reserved for future content]

6.6 Study Spaces

Practices

[reserved for future content]

6.7 Public Spaces

Practices

[reserved for future content]

6.8 Washrooms

Practices

[reserved for future content]

6.9 Kitchen and Lounge Spaces

Practices

[reserved for future content]

6.10 Service and Support Spaces

Practices

[reserved for future content]

6.11 Loading/Receiving Spaces

Practices

[reserved for future content]

6.12 Library Spaces

Practices

[reserved for future content]

6.13 Assembly Spaces

Practices

[reserved for future content]

6.14 Athletic Spaces

Practices

[reserved for future content]

6.15 Animal Spaces

Practices

[reserved for future content]

6.16 Residence Spaces

Practices

[reserved for future content]

SPECIFICATIONS

Preamble:

Included in the appendix are sections that clarify U of L design standards, including sections and tables referenced in the main body of the document. The appendix represents the preferences of various infrastructure disciplines including architectural, electrical, mechanical, controls, grounds and information technology services but in no way prevents design teams from proposing current or new uses which might be appropriate or will better meet performance requirements.

08 00 00 OPENINGS

08 06 00 Schedules for Openings

08 06 70 Door Hardware Schedule

- .1 Under the current agreement with the manufacturer, all keys and cylinders shall be shipped directly to the University.
- .2 The University shall supply a limited amount of construction cylinders for use during construction which must be returned upon completion of the project.

Table 08 06 70-1 – Acceptable Manufacturers for Door Hardware

Hardware Item	Acceptable Manufacturer
Keying – All keys and cylinders shall be visually keyed with the bitting list submitted to the University.	Corbin/Ruswin Patented 39 Series cylinders supplied with 2 keys per cylinder.
Locksets - Must meet or exceed ANSI operational & security grade 1 requirements.	Corbin/Ruswin (mortise lever lock) model LWA through bolted Trim X613. The Offices lockset functions shall be ML2055. Store Rooms lockset functions shall be ML2057.
Door closers - Must meet or exceed ANSI	LCN-4041 X 695, dark bronze, powder coated finish & handicap accessible.
Door Hold Open	LCN-4040 SE X 695
Panic Hardware - Must meet or exceed ANSI/UL	Von Duprin 98 RIM Device Series lever handle hardware X 313. Must accept above cylinders.
Electric Strikes: Rim Exit Device / Mortise Locks	Von Duprin 6111 / Von Duprin 6214
Electric Panic Hardware / Option	Von Duprin 98 EL with RX switch

08 81 00 Glass and Glazing General Requirements

- .1 A window shall be provided in all office and classroom doors to provide for some degree of visual surveillance. The requirements are:
- Classrooms and office doors will have the same glazing detail
 - Clear vision size = 125mm X 250mm
 - Vertical centre line = 1575mm
 - Horizontal centre line = 200mm
 - Passage door windows shall be 150mm X 410mm
 - Provide 230mm space between door frames and sidelight window frames to accommodate room identification and light switches.

09 00 00 FINISHES

09 06 90 Schedules for Painting and Coating

09 06 90.13 Paint Schedule

- .1 All paint types shall be as specified in the following table:

Table 09 06 90.13-1 Acceptable Manufacturers for Paint

Area	Paint Type	Acceptable Manufacturer
Wooden Doors	Guardsman Ultraguard Conversion Varnish	Varnish 3797-911350-505; Catalyst 3990-05005-505 Or Approved Equal
Metal Doors and Frames	Waterborne Acrylix Primer and Finish	Devoe Devflex Semi-Gloss 4216 HP Or Approved Equal
Textured Drywall	Drywall Primer/Sealer	Dulux 11000 Or Approved Equal
Drywall Primer/Sealer	Interior Latex High Hide Sealer	Glidden 36600 Or Approved Equal
Interior Walls (Drywall)	ICI	General Paint: Z-Coat Eggshell ICI: Life Master Eggshell Or Approved Equal
Q-Decking (Exposed Steel Ceiling)	Waterborne Flat	Spraymaster Pro Drywall Or Approved Equal
Gym Weight Room / Any Physical Activity Area	Waterborne Acrylic Semi-Gloss	Devoe Devflex 4216-00100 Or Approved Equal
Shower Rooms	Devoe Tru-Glaze Waterborne Epoxy	Product: 4406-00100 Catalyst: 4508-09999 Or Approved Equal
Concrete Floors to be painted	Devoe Tru-Glaze	Product: 4508 (Oil), 4508-00100 Catalyst: 4508-09999 Or Approved Equal

Mechanical Room Walls	Devflex Waterborne Acrylic Semi-Gloss	4216-00100 Or Approved Equal
Concrete Block	ICI	Block Filler 36250 Or Approved Equal

- .2 Walls shall be painted with an eggshell type of paint, with low VOC's.
- .3 All paint specifications shall be subject to minimum LEED standards.
- .4 Do not use water-based paints formulated with aromatic hydrocarbons (organic solvent with a benzene ring in its molecular structure), formaldehyde, halogenated solvents, mercury or mercury compounds, or tinted with pigments of lead, cadmium, chromium VI and their oxides. Water based paints shall be low VOC and shall have a flash point of 61 degrees Celsius or greater.
- .5 All paint types shall be as specified in Table 09 06 90.13-1 Acceptable Manufacturers for Paint as found in the Appendix.
- .6 For painting of mechanical and electrical work refer to the Specifications in the Appendix.

10 00 00 SPECIALTIES

10 06 00 Schedules for Specialties

10 06 20 *Schedules for Interior Specialties*

- .1 Soap dispensers shall be wall mounted; NOT located in the countertops.
- .2 All washroom walls shall be provided with a laminate backsplash.

10 06 20.13 *Toilet, Bath, and Laundry Accessory Schedule*

- .1 Acceptable washroom accessories shall be as per the following table:

Table 10 06 20-13 Acceptable Manufacturers for Washroom Accessories

Fixture Type	Acceptable Manufacturer
Soap Dispenser	Triad
Toilet Paper Dispenser	Scott Designer #09642 Junior Jumbo
Garbage Container	Rubbermaid #3520 half round containers
Garbage Cans	Rubbermaid Office Can #2596
Garbage Container	Rubbermaid Ranger #8430
Napkin Dispenser	Frost code #622
Recycle Bag Station	West Can Marketing
Double Napkin / Tampon Dispenser	Frost #608-3
Toilet Paper Dispenser (Handicap)	Frost #150

B.F. Stainless Steel Flip-up Shelf	Frost #955
Sharps container	

10 28 13 *Washroom Accessories*

- .1 Soap dispensers shall be wall mounted; NOT located in the countertops.
- .2 All washroom walls shall be provided with a laminate backsplash.
- .3 Toilet compartments shall be sturdy steel floor-mounted, overhead brace type with standard mounting screws. TAMPER PROOF SCREWS ARE NOT ACCEPTABLE.
- .4 Toilet compartment finish will be baked enamel.
- .5 Partitions located in shower areas should be overhead braced and of stainless-steel construction and installed with stainless steel fasteners.
- .6 Any accessories in shower must be stainless steel with stainless steel fasteners.
- .7 In accordance with the Alberta Barrier-Free Design Guide, all barrier-free washrooms will be fitted with a shelf mounted no higher than 1.2 m (3 ft. 11 in.) above the finished floor. For type, see Table 10 06 20-13 in Appendix.
- .8 A Sharps container for needles, lancets, etc. will be installed in washrooms as indicated on the architectural plans. Mount no higher than 1.2 m (3ft. 11 in.) above the finished floor. For type, see Table 10 06 20-13 in Appendix.
- .9 For more standards and acceptable manufacturers for washroom accessories see Table 10 06 20-13 in the Appendix.
- .10 All washroom vanities shall be provided with an integral backsplash to match vanity surface (plastic laminate, monolithic material, etc.).
- .11 Wall mounted toilet partitions are to be prefinished powder-coated steel. Floor, wall mounted, or brace type with superior mounting screws (no tamper proof fasteners) are all acceptable. Ceiling or overhead mounted partitions are not acceptable. Partitions and accessories within wet shower areas should be superior quality stainless steel with stainless steel fasteners.
- .12 Blocking is required in walls to properly mount all partitions, grab bars, etc., as required in steel stud partitions.
- .13 Washroom accessories shall be wall mounted and not located in counter tops. For additional information, refer to the washroom accessory table in the Appendix for a list of manufacturers currently in use.

11 00 00 EQUIPMENT

11 53 10 Laboratory Fume Hoods

- .1 Specific requirements for laboratory exhaust systems shall be reviewed with the University Safety and Risk Management Department and the University Project Manager. ANSI/AIHA Z9.5-2003 American National Standard for Laboratory Ventilation and NFPA-45 Standard on Fire Protection for Laboratories Using Chemicals shall be followed.
- .2 Design of fume hood exhaust systems should be in accordance with CSA Standard Z316, latest edition and the Minimum Guidelines for Laboratory Fume Hoods (PWGSC). Testing of fume hood performance as it pertains to installation and lab design shall follow ANSI/ASHRAE 110-1995 Method of Testing Performance of Laboratory Fume Hoods.
- .3 All systems shall have an adequate supply of make-up air tempered to room temperature.
- .4 All spaces shall be designed under negative pressure to adjacent spaces (Table 23 06 00).
- .5 Provide a duct wash-down system for all perchloric acid exhaust systems. Perchloric duct system must be dedicated.
- .6 Use Type 316 stainless steel ducts.
- .7 Provide a face velocity monitor on all fume hoods.
- .8 All laboratory hoods and safety cabinets shall be equipped with visual and audible alarms to warn laboratory workers of unsafe air flows (Alnor 335).
- .9 Provide an eye wash station in laboratories that have at least one fume hood. Design should be in accordance with ANSI A358.1-2004 Emergency Eyewash and Shower Equipment.
- .10 Where corrosive material is used in the laboratory, locate eyewash station within 3m of material.

14 00 00 CONVEYING EQUIPMENT

14 20 00 Elevators

- .1 All elevators require voice annunciation.
- .2 Access to elevators to conform to Barrier Free Standards.
- .3 Consider the design application of a freight elevator in all new buildings. Freight elevators must be sized to accommodate a 2.4m cart.
- .4 The Elevator Installation Contractor is to obtain and pay for certificates of approval and all other necessary permits, inspections and re-inspections, if necessary, due to any failure of any elevator equipment.
- .5 The Elevator Installation Contractor is to pay all patent licensing fees and royalties necessary for the completion of the contract and the University will not be held responsible for infringements of patents of the elevator subcontractor in the completion of his contract.
- .6 Freight elevators should be located adjacent to service entrances, service corridors and loading docks as applicable.
- .7 Provide roller guides consisting of polyurethane-tired wheels, at least 150mm diameter for the car guides and 75mm diameter for counterweight guides here applicable for all passenger elevators.
- .8 Guides on freight elevators shall consist of solid slippers or sliding guide shoes.
- .9 In regard to rails, Standard size "T" section car and counterweight guide rails, with tongue and groove joints, together with suitable splice plates at the connections are required.
- .10 For Car Top Guardrails, provide a substantial metal guardrail on the sides and back of the car top. The guard rails shall conform to most recent ASME A17.1/CSA B44, Safety Code for Elevators and Escalators for loads and placements. Top rail located approximately 1070mm above the car top and an intermediate rail located approximately 1066mm above the car top. A 125mm toe board shall be provided at the base of the guard.
- .11 Automatic car door operators shall be of the heavy-duty, high-performance type designed for high performance and long life. Light or medium duty door operators are not acceptable.
- .12 Front and rear door arrangements should be avoided and used only where the design of the building makes any other solution impossible. When centre opening doors are provided, the elevator cab shall have two car operating panels, one on each side of the cab. Where front and rear doors are used the elevator cab shall have two car operating panels, one on the front side and one on the rear side of the cab. Where space permits car operating panels shall be mounted on the door return panels, otherwise on the side walls adjacent to the door return panel.

- .13 Where possible mount the car call buttons in a single vertical column.
- .14 In-Car stop switches shall be key operated.
- .15 Where possible mount the car call buttons in a single vertical column.
- .16 Any elevator equipped with Phase I Emergency Recall shall also be equipped with Phase II In-Car Emergency Service Operation and the related keyed switch.
- .17 A battery powered emergency cab light device shall be provided for each elevator. The illumination source shall be an integral part of the car operating panel or as a separate inconspicuous fixture.

22 00 00 PLUMBING

22 05 00 Common Work Results for Plumbing

- .1 Mechanical Department requires a minimum of 48 hours' notice when tying into existing building mechanical systems. This includes:
 - Domestic cold-water piping
 - Domestic hot water piping
 - Chilled water piping
 - Hot water heating piping
 - Glycol heating piping
 - RO piping
 - Compressed air system piping
 - Fire protection piping
- .2 The University will decommission all existing systems.
- .3 Mechanical rooms shall be provided with at least one non-freeze hose bib with back flow preventer.
- .4 Mechanical rooms shall be provided with a minimum of one floor drain.
- .5 Provide a mop sink in all mechanical rooms that contain any of the following items: air handling units, pumps, boilers, chillers, sump pits.
- .6 Provide an additional floor drain in mechanical rooms near any of the following items: air handling units, pumps, boilers, chillers, sump pits.
- .7 The University has a standard for tagging of equipment. This may be obtained from the University Utilities department.
- .8 All drawings must include a schedule of all equipment (including Chiller, Pumps, VAVs, RHC, etc.). These schedules should itemize the parameters for balancing and the location of service areas. Schedules are to be provided electronically in spreadsheet format. Consult the University Engineering department for more information.

- .9 For mechanical rooms not accessible to an elevator, provide a lifting device and supports to move heavy equipment up and down stairs safely and easily.
- .10 Drain valves are required downstream of branches serving areas on DCW, DHW, and DHWR. Provide shut-off valves for these lines on every level of the building.
- .11 Double nut hangers on all thread after lead adjust on 2" (50mm) pipe and smaller.
- .12 Ball valves required for all gauges and auto vents.
- .13 All gauges to be liquid filled, minimum size 63mm.
- .14 All mechanical piping to be supported from above. No floor supports.
- .15 Use lug type butterfly valves 2.5 inches and up.
- .16 SPARE PARTS LIST. As applicable, the following is to be provided at the completion of construction:
 - One rebuild kit for each faucet, flushometer, PRV, backflow and wall hydrant installed.
- .17 For specified Piping and Valve Identification legend please refer to Table 22 05 53-1 in the Appendix.
- .18 For acceptable manufacturers for plumbing equipment please refer to Table 22 06 30-1 in the Appendix.

22 05 53 Identification for Plumbing Piping and Equipment

- .1 Provide directional arrows on all lines indicating the direction of fluid flow, as applicable.
- .2 Refer to Table 22 05 53-1 for the piping and valve identification legend and colours:

Table 22 05 53-1 Piping and Valve Identification Legend

Pipe Marker Legend	Valve Tag Legend	Primary Colour	Band Colour
Chilled Water Supply	CH.W.S.	Green	Red
Chilled Water Return	CH.W.S.	Green	Red
Domestic cold Water	D.C.W.	Green	None
Domestic Hot Water Supply	D.H.W.S.	Yellow	Green
Domestic Hot Water Recirc.	D.H.W.R.	Yellow	Green
Heating Water Supply	H.W.S.	Yellow	None
Heating Water Return	H.W.R.	Yellow	None
Reheat Water Supply	R.H.S.	Yellow	None
Reheat Water Return	R.H.R.	Yellow	None
Glycol Supply	Gly.S.	Purple	None

Glycol Return	Gly.R.	Purple	None
Storm Sewer	St.S.	L. Blue	None
Sanitary Sewer	San.S.	Brown	None
R.O. Water	R.O.	White	None
Compressed Air	C.A.	Med. Blue	None
Fire Protection Water	F.P.W.	Red	White
Sprinkler Water	S.W.	Red	White
Vent Piping Plumbing	V	Brown	Blue
Natural Gas	GAS	Yellow	None

- .3 Provide data dot labels on all T-bar frame and access panel identification for all concealed areas. Refer to the following table (Table 22 05 53-2) for required duct access door labels:

Table 22 05 53-2 T-Bar and Access Dots

Item	Colour
Cleaning and Service Access	Yellow
Control Devices	Black
Dampers (Backdraft, Balance, Control)	Blue
Dampers (Fire)	Red
Smoke Dampers & Detectors	Red
Pipe Mounted Devices	Blue

22 06 00 Schedules for Plumbing

- .1 Submit alignment reports for pumps and fans after installation is complete.

22 06 10 Schedules for Plumbing Piping and Pumps

- .1 Provide pump curves.

22 06 30 Schedules for Plumbing Equipment

Table 22 06 30-1 Acceptable Manufacturers for Plumbing Equipment

Item Description	Acceptable Manufacturer
Access Doors	Maaxam, Acudor, Milcor, Can.Aqua, Mifab
Air Compressors	Hydrovane, Champion
Air Dryers	Deltech, Cactus
Air Vents	Honeywell Braukmann, Watts, Taco, Amtrol
Backflow Preventers	Watts (No Equals)
Commissioning Agents	University of Lethbridge
Cleanouts	Ancon, Jay R Smith, Zurn
Drains – Floor, Roof, Cleanouts, Trap Primers, Water Hammer Arrestors	Zurn, Ancon, J.R. Smith
Drinking Fountains (Hand Operated)	Oasis
Expansion Compensators	Flexonics, United Flexible
Expansion Joints	Flexonics, United Flexible
Eye Wash Fountains	Western, Haws, Bradley, Encon
Fire Extinguishers	Ansul, Flag, Kidd, Pyrene, Pryo-chem
Fire Extinguisher Cabinets	CFH Industries, Impaction Firequip Inc., National Fire Equipment, Wholesale Fire and Rescue Ltd.
Fire Hydrants	McAvery M-67 (No Equals)
Flexible Connectors – Piping	Flexonics, United Flexible, Mueller, Flexpipe
Floor Drains	Ancon, Jay R Smith, Zurn
Floor Trap Primers	Zurn 1022
Gauges – OWG Pressure (liquid filled, stainless steel)	Ashcroft, Weiss
Gauges – Temperature	Trend
Grooved Mechanical Pipe Joints – Heating/Water & Fire Protection Systems	Victaulic
Hangers	Grinnell
Insulation – Piping and Duct	Fibreglass Canada, Manson, Knauf Manville
Jacketing – Canvas	Alpha Maritex, Clairmont, Diplag, S Fattal Thermocanvas
Meters – Water (m ³)	Neptune
Meters – Gas (ft ³)	Roots, Canadian Meter
Piping Hangers and Saddles	Grinnell, Myatt
Plumbing Trim	American Standard, Powers, Crane, Symmons, Delta, Sloan
Plumbing Fixtures	Crane, American Standard, Arista Newman, Haws, Bradley, Western, Sloan
Pumps – In-Line Circulators (General)	Grundfos
Pumps – In-Line DHWR	Grundfos (stainless steel body c/w bronze flanges)
Pumps – Sump	Grundfos (stainless steel)
Pumps – Seals	Type 21

Pumps – Sewage Lift	Hydromatic, Tsurumi
Pumps – Vertical In-Line and Base Mounted	Armstrong, B & G, Taco, Grundfos, Aurora
Regulators – gas	Fisher
Reverse Osmosis	ROH ₂ O systems
Roof Drains (Cast Domes Only)	JR Smit, Zurn
Sanitary and Storm Manholes	Follow City of Lethbridge standards
Sinks – Specialty	Fiat, Cambridge
Sinks – Stainless Steel	American Standard, Kindred (Aristaline)
Sinks – Trim	Delta (No Equals)
Strainers	Armstrong, Metraflex, Kitz
Thermometers	Terrice
Valves – Butterfly (over 50mm) – Lug type only	Keystone, DeZurik, Centreline, Crane, Toyo, Kitz, Apollo
Valves – Check	Crane, Toyo
Valves – Backwater ABS	Bow, Canplus, Zurn, Watts, JR Smith
Valves – Ball (Soft Closing)	Jenkins, Toyo, Crane, MA Stewart
Valves – Globe	Bonney Forge
Valves – Silent Check	Val-matic, Metraflex, Bonney Forge
Solenoid Valves	ASCO – (No Equals)
Valves – Water Pressure Reducing	Watts
Vibration Isolation	Mason, Vibro Acoustic, Korfund
Wall Hydrants – non freeze	JR Smith
Water Closets (6L)	American Standard Champion 4, Cadet 4
Water closets – Seat covers	American Standard
Water Hammer Arrestors	Amtrol, JR Smith

22 08 00 Commissioning of Plumbing

- .1 The University reserves the right to inspect and camera all underground storm, weeping tile and sanitary sewer piping prior to being permanently covered.
- .2 All piping shall be pressure tested prior to receiving insulation.
- .3 Pressure test all plumbing lines to 1.5 times system operating pressure or as specified by the Design Consultant, whichever is more stringent.
- .4 All pressure testing shall be witnessed and signed off by the Contractor and a University Representative.

22 10 00 Plumbing Piping and Pumps

22 11 00 Facility Water Distribution

22 11 13 Facility Water Distribution Piping

- .1 Piping shall be pitched, and valves installed to allow for complete drainage of system.
- .2 All piping run within the building shall be concealed in the finished portions of the building in pipe spaces, ceilings or chases wherever possible.
- .3 No pipe shall pass in front of or interfere with any openings, doors or windows. No pipe shall pass in front of or interfere with clearances around mechanical equipment.
- .4 Piping shall not pass exposed through electrical or telecom rooms or be erected over any switchboard or other electrical gear unless required by Fire Code.
- .5 Piping shall be installed with adherence to the National Plumbing Code, the Alberta Building Code and all local authorities.
- .6 Maintain a minimum of 50mm clearance between all insulated piping and other obstructions.
- .7 Strainers are required before all PRVs and backflow prevention devices.
- .8 Bypasses shall be installed around all water meters and control valves.
- .9 Provide fireproofing material and caulking in the space between all sleeves and pipes.
- .10 Where pipes pass through fire-rated partitions, the space around the pipes shall be sealed and/or filled with fireproofing sealers.
- .11 All equipment drain lines shall be piped and sloped to the nearest possible floor drain. Provide appropriate trapping, where required.
- .12 Use instantaneous potable hot water systems. Provide heat exchangers tied into the hot water distribution system, wherever possible. Avoid the use of gas fired domestic water heaters.
- .13 All systems shall be designed and installed as per the National Plumbing Code, latest edition.
- .14 Use only type L piping hand drawn copper tubing for all weather piping. Joints shall be made with no-lead solder.
- .15 Water hammer arrestors shall be installed on cold water piping to toilet rooms where flush valves are used. Use water hammer arrestors for all quick acting automatic valves supplying equipment.
- .16 Provide a meter on the following services upon entering the new building, gas, water, electrical.
- .17 Backflow prevention devices shall be a minimum of ¾" (75mm) in size.

22 11 16 *Domestic Water Piping*

- .1 PRV's installed in pairs parallel.
- .2 Backflow device complete with air gap fitting. Backflow size: minimum ¾" (19mm).
- .3 All domestic water lines are to be copper.

22 13 00 **Facility Sanitary Sewerage**

- .1 The consultant in conjunction with the Utilities Department will determine the locations of sanitary sewer service tie-ins. All tie-in methods must be approved by the Utilities Department.
- .2 Pipe Clamps for above grade sanitary and storm drains in use on campus are Fernco or MJ clamps.
- .3 Manhole covers are to be identified by cast-in language indicating "storm sewer" and "sanitary sewer".

22 14 00 **Facility Storm Drainage**

- .1 University of Lethbridge will inspect and camera all building weeping tile conduits prior to burial. Adequate cleanouts for weeping tile systems to be provided so all areas can be inspected with camera. On straight runs cleanouts to be spaced 25m apart. Bends or corners in weeping tile require additional cleanouts.
- .2 The consultant in conjunction with the Utilities Department will determine the locations of storm sewer service tie-ins. All tie-in methods must be approved by the Utilities Department.
- .3 Surface and subsurface considerations should be made for proper grading and drainage of storm water around buildings and through public spaces in the event of significant rainfall or heavy snow melt.
- .4 The consultant in conjunction with the Grounds and Utilities Department will determine the location of storm water drainage paths and below grade service tie-ins. All tie-in methods must be approved by the Utilities Department.

22 40 00 **Plumbing Fixtures**

- .1 All drawings must include a schedule of all fixtures and equipment (including chiller, pump, VAV, RHC, etc. schedules). These schedules should itemize the parameters for balancing and the location of service areas or zones.
- .2 Dashed lines for equipment on drawings should be indicative of the required space area necessary for access and maintenance (i.e., coil pulls, motor access, etc.).
- .3 Domestic hot water is to have re-circulating piping complete with balancing valves where hot water supply piping exceeds 15 m (50 feet). Branch piping from a manually operated faucet to a

circulated main shall not exceed 8m (25 feet) or 3 m (10 feet) for a hands-free faucet. Provide flow measurement valves for each major branch of the domestic hot water recirculation system.

4. Water and wastewater systems are to be designed and installed without concealment of mechanical compression style joints. All grooved piping systems for use with copper tubing are to be manufactured to copper tube dimensions (i.e., no flaring of tube ends to accommodate alternate sized couplings).
5. Provide isolation valves in accessible locations on supply and return mains, at the bottom of each riser, branch lines and mains, each washroom group, individual fixtures and non-freeze hose-bibs. Provide additional valves on a recirculating hot water system to prevent total system isolation of piping should leaks or other problems arise.
6. Provide non-freeze key operated hose bibs at no more than 30.5 m (100 feet) spacing at the building perimeter. Coordinate the location of hose bibs required on each building face with Grounds and Utilities.
7. Fixtures to be utilized are to be of low-flow rates where standard water closets do not exceed 4.8 litres per flush (LPF), dual flush water closets 6/4.2 LPF and urinals 0.5 LPF. Waterless urinals are not permitted. Lavatory faucets are to not exceed a rate of 1.9 litres per minute (LPM) and showers 6.8 LPM.

22 42 00 Commercial Plumbing Fixtures

- .1 LEED standard flow requirements shall be used as a minimum for all plumbing fixtures.
- .2 Supply tubes used for all plumbing fixtures to be braided stainless steel hose.
- .3 No screwdriver stops for shutoffs, use ball valves.
- .4 Use electrical power for automated sensor fixtures.
- .5 Wall hydrants to be recessed chrome, concealed with vacuum breaker.

22 42 13 Commercial Water Closets, Urinals, and Bidets

- .1 Floor mounted dual flush, low flow water closets shall be used for all applications. Refer to acceptable manufacturers' list (Table 22 06 30-1).

22 42 16 Commercial Lavatories and Sinks

- .1 Refer to architectural specifications for wall anchorage prior to the installation of plumbing fixtures.
- .2 Provide infrared hands-free water flow activation with all new construction and renovated lavatories.

- .3 Provide adequate wall access to valves for maintenance on all fixtures.
- .4 Service sinks are to have back splash protection on two sides minimum.
- .5 Provide recessed DHW hose bibb connection underneath lavatory in all washrooms with urinals. Conceal hose bibb with access door mount flush with the wall.
- .6 Refer to acceptable manufacturer's list for more details (Table 22 06 30-1).

22 47 13 *Drinking Fountains*

- .1 Provide flexible bubbler guard on water fountains.

23 00 00 GENERAL REQUIREMENTS

- .1 In regard to common work results for HVAC, the following outdoor conditions are applicable:

All ambient weather design information shall be as supplied by the Alberta Building Code:

- Lethbridge Design Conditions:
- Elevation: 910m
- Design Winter DB: -30°C
- Design Summer DB: 31°C
- Design Summer WB: 18°C

- .2 Indoor conditions include:

- .1 All spaces listed in Table 23 06 00-1 specify maximum and minimum occupancy temperatures. The maximum shall be used for summer and the minimum for winter design conditions.
- .2 For zone relative humidity requirements, refer to the air handling section, unless otherwise noted.
- .3 All ductwork shall be pressure tested as per the SMACNA Standards for Leak Testing Ductwork.
- .4 All hangers and spacing shall be as per SMACNA Standards.
- .5 The University has a standard for tagging of equipment. This may be obtained from the University Utilities department.
- .6 All drawings must include a schedule of all equipment (including Chiller, Pumps, VAVs, RHC, etc.). These schedules should itemize the parameters for balancing and the location of service areas. Consult the University Engineering department for more information.
- .7 A dashed area line should be shown on the drawings where equipment requires area for maintenance and access (i.e., coil pulls, motor access).

- .8 Air handling units shall be located with adequate space for maintenance and coil pulls. Where an area does not appear to meet this criterion, it shall be noted to the University.
- .9 Avoid the use of mechanical rooms as air plenums.
- .10 For mechanical rooms not accessible to an elevator, provide a lifting device and supports to move heavy equipment up and down stairs safely and easily.
- .11 Provide access doors for maintenance with all air intake dampers/louvers.
- .12 Marine lights for inspection shall be in all sections. Lights should be wired to a single switch located on the outside of the air handling unit.
- .13 Provide two lights in each fan and filter module.
- .14 Provide inspection windows in all fan sections as a minimum.
- .15 Provide a minimum of one 115V receptacle on the outside wall near middle section of air handling unit.
- .16 Spare parts list. As applicable, the following is to be provided at the completion of construction:
 - .1 Spare belts for each fan installed.
 - .2 Spare seal for each pump installed.
 - .3 One set of bag filters for each AHU installed
 - .4 Four sets of pre-filters for each AHU installed.
 - .5 One complete gasket set for each heat exchanger installed.
- .17 All university spaces shall be designed according to ASHRAE Standard 62-04 (or latest version) or Table 23 06 00-1, whichever is more stringent.
- .18 Coordinate the number of hose bibs on each building face with the University. Hose bib spacing is to be no more than 15 m (50') apart.

23 20 00 HVAC Piping and Pumps

- .1 Make up water meters for HWH or CW to be measured in m³ (tenths) one litre.
- .2 All gauges to be liquid filled, minimum size 63mm.

23 21 00 Hydronic Piping and Pumps

- .1 General

- .1 Standby pumps shall be provided for all hot water heating and distribution systems.
 - .2 All pumps shall have bronze impellers.
 - .3 Pump schedules shall indicate system served, operation (primary or backup), flow, pump head, rpm, motor horsepower, location, make and model number and electrical characteristics.
 - .4 All inlet and outlet piping to pumps shall provide minimum losses wherever possible, check valves and strainers required.
 - .5 Pumps should be provided with suction guides, discharge diffusers or check valves and strainers, as required.
 - .6 Pump seals shall be provided by John Crane Seals Type 21. No equals.
 - .7 Pumps shall be installed on supported slabs and shall be provided with concrete inertia sub-bases with spring isolators.
 - .8 Pumps installed on "Slab on Grade" vibration pad shall be mounted on a 150mm high concrete pad with anchor bolts. The space between pad and base shall be grouted to eliminate all voids.
 - .9 All piping connections to pumps shall be supported independently so that no strain is imposed on the pump casing.
 - .10 Triple duty valves and suction diffusers shall be of the same manufacturer as the pump supplier in all cases.
 - .11 Pumps shall be provided with variable frequency drives, wherever applicable.
 - .12 Drain valves are required downstream of branches serving areas on DCW, DHW, and DHWR.
 - .13 Double nut hangers on all thread after lead adjust on 2" (50mm) pipe and smaller.
 - .14 Use lug type butterfly valves 2.5 inches and up.
 - .15 Submit Laser alignment reports for pumps & fans.
 - .16 Refer to acceptable manufacturer's list (Table 23 06 00-2) for more pump details.
 - .17 For acceptable valves suppliers, refer to the acceptable manufacturer's list (Table 23 06 00-2).
- .2 Valves
- .1 All valves for any one project shall be the product of one single manufacturer.

- .2 Valves shall be installed with the bonnet in the upright position to prevent deterioration or corrosion of the bonnet and packing.
- .3 Valve body materials shall be compatible with piping system materials.
- .4 A valve drain shall be provided at the base of each water piping riser and automatic air vents shall be provided at the top of each riser and at the high point of the system.
- .5 Use ball valves for all sizes up to 50mm.
- .6 Provide extended stems where required.
- .7 Use butterfly valves for all sizes over 50mm.

23 21 13 *Hydronic Piping*

23 21 13.23 *Aboveground Hydronic Piping*

- .1 All mechanical piping to be supported from above. No floor supports.

23 23 00 **Refrigerant Piping**

- .1 Refrigerant liquid and suction piping shall be type L hard drawn ACRS tubing.
- .2 A nitrogen purge shall be maintained when soldering all joints. Copper to copper joints shall be made with brazing alloy like Sil-Fos. Copper to brass joints shall be made with silver solder.
- .3 Main piping fittings for dryers, sight glasses, expansion valves, and controls shall be flare or compression type fittings.
- .4 Prior to being charged with refrigerant, the system shall be evacuated to 500 microns and held for at least 24 hours under this vacuum.
- .5 Install all refrigerant piping as per specific equipment manufacturer's recommendations.
- .6 Install isolation valves at all refrigerant system accessories.
- .7 Installations shall be complete with dryers, sight glass and thermostatically controlled solenoid valves for pump down operations.
- .8 Installations shall be provided with necessary protective device including, but not limited to, electric overload devices, low-suction pressure cut-outs (manually reset), oil traps, crankcase heaters and anti-recycling.
- .9 Outdoor condensing systems to be used year-round, without air handling unit free cooling, shall be designed for -30°C ambient conditions.

- .10 Outdoor condensing systems to be used year-round with air handling unit free cooling, shall be designed for -10°C ambient conditions.
- .11 Dual circuited refrigerant systems shall be designed with intertwined air handling coils.

23 30 00 HVAC Air Distribution

- .1 General
 - .1 All air handling systems should be designed with:
 - Accordance to Table 23 06 00-1 and all applicable standards.
 - Free cooling.
 - Variable air Volume complete with VFD zone static pressure fan control.
 - Carbon dioxide monitoring and control.
 - .2 Use custom type air handling units as a standard of design for all units greater than 10,000 LPS. For all units less than 10,000 LPS it is possible to provide standard modular type air handling units. For a complete list of acceptable manufacturers, refer to Table 23 06 00-2. Consult with University prior to the design of an air handling unit for preferred components and manufacturers.
 - .3 Air handling units should be tied into the central chilled water and hot water systems of the building, wherever possible.
 - .4 Packaged DX refrigeration air handling units shall not be used for standard design systems unless it is in a special process application. All use of DX refrigeration including heat pumps must have approval by the University.
 - .5 Standard design of air handling units based on 2.0m/s (400fpm) face velocity.
 - .6 Use all methods of heat recovery for energy efficient operation, where possible.
 - .7 Provide double wall casing for all units. Interior wall perforated liner may be provided in fan sections only.
 - .8 Air handling units shall be in mechanical rooms. Do not use rooftop air handling units unless approved by the University.
 - .9 Use air blenders with mixed air units.
 - .10 Air handling units shall be ARI tested and certified. If a unit is not ARI certified, a factory performance inspection is required.
 - .11 All drain lines from the air handling units shall be piped and trapped appropriately.
 - .12 Provide fan curves.
 - .13 Submit laser alignment reports for pumps and fans after installation is complete.

.2 Coils

- .1 Provide automatic air vents at all hydronic coils at the highest point.
- .2 Coils shall be fully drainable and piped for counter-flow operation.
- .3 Coils should not be selected with more than 120 fins per inch.
- .4 Provide stainless steel IAQ sloped drain pans at all cooling coils.
- .5 Hot water, chilled water and refrigeration coils shall be ARI certified and tested.
- .6 Each coil shall have isolation valves on supply and return.

.3 Humidification

- .1 Provide humidification in all air handling units with stainless steel mounting frames.
- .2 Use Munters Media type for all humidification and evaporative cooling. Media cooling shall be set up for a 'once through' application. Pumped return systems are not acceptable. Media sections shall be piped to allow for multiple staging of the system. Piping with solenoid should be brought to the outside of the unit for accessibility.
- .3 The use of steam injection humidification is not acceptable.
- .4 Water used for humidification shall be individually metered at the device.

23 33 00 Air Duct Accessories

23 33 13 Dampers

- .1 Low leak dampers (2%) should be used as a minimum. Refer to acceptable manufacturers list for more information.
- .2 Fire dampers to be accessible for maintenance. Dampers that are not accessible will be removed and the contractor is responsible for providing suitable access.
- .3 Locate all balancing dampers in the duct take-offs. Diffusers supplied with a balancing device inherent in the device will not be accepted.
- .4 Supply dampers are to be in the ductwork, not an integral part of the diffuser housing.

23 34 00 HVAC Fans

- .1 Frames for humidification in AHU's are to be stainless steel.

23 36 00 **Air Terminal Units**

23 36 16 *Variable-Air-Volume Units*

- .1 Variable Units:
 - .1 Design and indicate in schedule minimum ventilation requirements for each zone.
 - .2 Use reheat coils on all boxes for temperature control, where required. For more information see Terminal Heating Units section.
 - .3 Provide VAV boxes to site with factory mounted DDC controls.
 - .4 VAV schedule shall include minimum and maximum Airflows, noise criteria levels, and coil ratings.
 - .5 Where more than one box is required to control a single zone, zone shall be controlled with only one temperature sensor.
 - .6 Boxes should be in corridors and common areas wherever possible. Avoid locating boxes above classrooms and offices.
 - .7 Provide reheat coils with all variable volume boxes, where required.
 - .8 Reheat coils shall be designed for a minimum of a 17°C water temperature differential.
 - .9 Refer to acceptable manufacturer's list (Table 23 06 00-2) for vendor details.
- .2 Zoning:
 - .1 Offices:
 - .1 Zone all offices with similar configuration and load type.
 - .2 Offices shall be zoned to allow for 2 to 3 rooms with one Variable Air Volume Box control.
 - .3 Locate temperature sensor in an area out of direct sunlight and on an interior wall. Locate the sensor 100mm above the light switch within 300mm of outer edge of door frame.
 - .2 Classrooms:
 - .1 Classrooms shall be zoned individually.
 - .2 Locate temperature sensor in a common area out of direct sunlight and on an interior wall. Locate the sensor 100mm above a light switch and/or within 300mm of outer edge of door frame.

.3 Use displacement ventilation in classrooms where permitted.

.3 Other:

.1 Where areas with different operating schedules are served by one air handling unit, provide a means of area isolation to reduce air flow and energy usage.

.2 Zone air systems with similar space function, occupied hours and air quality requirements.

23 37 00 Air Outlets and Inlets

.1 Drain pans shall be stainless steel and double sloped. Locate drain pans in the first module of all air handling units.

.2 Air intake systems should be designed with a means of snow/moisture removal (i.e....mist eliminators, specific duct designing). Ductwork drains should be provided at all air intakes where required. Avoid all West facing air intakes where possible and always consider the Lethbridge wind in all designs.

.3 Ensure adequate spacing between exhaust and intake louvers.

.4 Low leak type dampers (2% leakage) shall be used as minimum quality.

23 40 00 HVAC Air Cleaning Devices

.1 Main supply air handling units shall be equipped with 24 X 24 inch 85% efficient Defiant material/synthetic bag type filtration with (fibreglass) FL Gold pre-filters. Cartridge filters are not acceptable on any air handling units. Refer to acceptable manufacturers list (Table 23 06 00-2).

.2 Air handling units shall be designed with a summer and winter pre-filter location.

23 50 00 Central Heating Equipment

23 52 00 Heating Boilers

.1 Boilers

.1 Select boilers with a full 100% redundancy.

.2 Fire tube type boilers should be used for capacities above 1500kW.

.3 Water tube flex boilers should be used for capacities below 1500 kW.

.4 Boilers shall be selected based on hot water distribution only. Steam boilers are not acceptable.

- .5 Heat recovery devices such as boiler flue economizers should be provided wherever possible.
- .2 Heating Distribution
 - .1 Design hot water heating distribution with a minimum temperature drop of 15C across any end device.
 - .2 Provide variable volume flow on all secondary distribution systems. Pumps to be supplied with variable frequency drive.
 - .3 Allow for 100% redundancy in all heating distribution systems.
 - .4 Allow for all terminal units (wall fin radiation, reheat coils, etc.) to be on a separate loop with a separate distribution pump. Provide a three-way mixing valve to allow for temperature reset of the terminal devices.
 - .5 For further information see Section on Pumps and Hydronic Piping Systems.
 - .6 Side stream filter required for all heating systems.

23 63 00 Refrigerant Condensers

- .1 The manufacturer's minimum recommended clearances, including distances from landscaping, shall be maintained.
- .2 Where water cooled condensing units are required, cooling towers, evaporative condensers or a closed loop cooling system shall be used. A once through cooling water to waste system is not permitted without the approval of the University.

23 64 00 Packaged Water Chillers

23 64 16 Centrifugal Water Chillers

- .1 Water Chillers
 - .1 Centrifugal water chillers should be utilized for all proposed loads over 352 kW (100 tons). For loads of under 352 kW, consult with the University prior to selecting a cooling source.
 - .2 Select all chillers based on a comparison of efficiency versus cost.
 - .3 Select chilled water systems for 5.6C (42F) Leaving Water Temperature. Base the Return Water Temperature on the design of the system. Optimize the temperature differential wherever possible.
 - .4 Refrigerant selection shall be discussed with the University Utilities Department prior to equipment selection.

- .5 Chillers shall be selected based on peak load efficiency and all part loads shall be shown according to ARI Standard 550/590-1988.
 - .6 Chiller control panel interfaces shall be capable of communicating on the University Building Control system. Consult the University Utilities Department for exact requirements.
 - .7 Chillers shall be CSA/CUL and ARI certified.
 - .8 Chillers shall be selected for 100% load. No additional load redundancy is required unless the application demands. It is acceptable, cost permitting, to provide two chillers sized at half of the total chilled water load.
 - .9 Provide adequate maintenance for all chilled water equipment in mechanical space. Drawings should reflect an outline of the manufacturer's suggested access areas.
 - .10 Refer to the Acceptable Manufacturer's List (Table 23 0-6 00-2) for approved chiller suppliers.
- .2 Cooling Distribution:
- .1 Provide variable frequency drives on all chilled water distribution pumps.
 - .2 All pumps shall have bronze impellers.
 - .3 Pump schedules shall indicate system served, operation (primary or backup), flow, pump head, rpm, motor horsepower, location, make and model number and electrical characteristics.
 - .4 All inlet and outlet piping to pumps shall provide minimum losses wherever possible, check valves and strainers required.
 - .5 Pump seals shall be provided by John Crane Seals, no equals.
 - .6 Pumps shall be installed on supported slabs and shall be provided with concrete inertia sub-bases with spring isolators.
 - .7 Pumps installed on "Slab on Grade" shall be mounted on a 150mm high concrete pad with anchor bolts. The space between pad and base shall be grouted to eliminate all voids.
 - .8 All piping connections to pumps shall be supported independently so that no strain is imposed on the pump casing.
 - .9 Triple duty valves and suction diffusers shall be of the same manufacturer as the pump supplier in all cases.
 - .10 Pumps shall be provided with variable frequency drives, wherever applicable.

.11 Refer to acceptable manufacturer's list (Table 23 06 00-2) for more pump details.

.12 Pump bases to be grouted.

23 65 00 Cooling Towers

- .1 Provide direct evaporative cooling towers. Indirect cooling towers may also be used, budget permitting.
- .2 Provide chemical treatment for all open direct cooling towers.
- .3 Provide electric sump heater for cooling tower operation to -10C.
- .4 Locate cooling towers away from common walkways.
- .5 All outside water lines for cooling tower to be insulated and complete with heat tape.
- .6 Make up water to be metered to cooling tower.
- .7 Cooling tower fan motor to be supplied with variable frequency drive.

23 80 00 Decentralized HVAC Equipment

23 82 00 Convection Heating and Cooling Units

23 82 36 Finned-Tube Radiation Heaters

- .1 Cabinet shall be constructed with a minimum of 14 gage metal enclosure.
- .2 Finned tube radiation shall be designed for a minimum of 17°C temperature differential.
- .3 Cabinet shall be installed around the perimeter of all buildings.
- .4 Finned Tube Radiation shall be designed such that it provides all nighttime heating for buildings. Designing buildings to heat at night with air handling systems is not acceptable.
- .5 Radiant heating panels should not be used unless approved by the University.
- .6 Design of all storage areas should incorporate finned tube radiation. Unit heaters are not to be used in this application unless approved by the University.

25 00 00 **INTEGRATED AUTOMATION**

25 05 00 **Common Work Results for Integrated Automation**

25 05 53 *Identification for Integrated Automation*

- .1 Identify all systems, equipment, components, controls and sensors with laminated plastic tag indicating point identification name, point address (program name), control panel, control panel location.

25 30 00 **Integrated Automation Instrumentation and Terminal Devices**

25 35 00 **Integrated Automation Instrumentation and Terminal Devices for HVAC**

25 35 16 *Integrated Automation Sensors and Transmitters*

- .1 Temperature Sensors:
 - .1 Temperature Sensor with Local Adjustment: The local adjustment shall enable the occupant to adjust the temperature within the temperature range that is pre-set from the building Management System.
 - .2 Temperature Sensor with Local Temperature Display: This feature shall enable the occupant to view a digital display of the existing temperature in that room.
 - .3 Provide sensors as per table 25 35 26-1:

Table 25 35 26-1 **Temperature Sensor types**

Room	Local Adjustment (Y/N)	Local Temp. Display (Y/N)	Temperature Range (°C)
Office	Y	Y	20-24
Classroom	N	N	20-24
Meeting Rooms	Y	Y	20-24
Common Areas	N	N	20-24
Computer Rooms	N	N	20-24
Laboratories	N	N	20-24
Storage Areas	N	N	20-24

- .4 For a list of acceptable products please refer to the acceptable manufacturers list (Table 23 06 00-2). Any changes in the supply of any temperature sensors shall be subject to University approval.
- .2 CO2 Sensors:
 - .1 Use infrared style CO2 sensors only. Refer to acceptable manufacturers list (Table 23 06 00-2) for more information.
- .3 Wiring
 - .1 All control wiring shall be installed in conduit, unless approved otherwise.

25 90 00 Integrated Automation Control Sequences

25 94 00 Integrated Automation Control Sequences for Plumbing

- .1 Weeping Tile Sumps and Sanitary Sumps on Emergency Power.
 - .2 Provide redundant pumps in all sumps.
 - .2 Provide a high-level alarm for each sump compartment.
 - .3 Provide a pump status at the BMS for each pump.
 - .4 Check valves to be plastic PVC type on all sump piping systems.
 - .5 Drainage tile system cleanouts shall be provided in order to be able to flush the lines.
 - .6 Refer to the Acceptable Manufacturer’s List (Table 23 06 00-2) for more information.

25.94.01 *Safety Showers / Eye Wash Stations*

25.94.02 *Storage Tanks*

25.94.03 *Vibration Isolation*

25 95 00 Integrated Automation Control Sequences for HVAC

- .1 Provide programming and hardware necessary to operate mechanical systems as per the following, unless otherwise approved by the University.
- .2 Provide a points list for all projects itemizing which points are analog input, analog output, digital input and digital output. Points should be shown under the proposed panel they are intended to be wired to.
- .3 System Start/Stop Routines:
 - .1 Occupied time: Equipment shall be controlled based on the University time of day scheduling for each area. Consult the University for the current schedule.
- .4 Air Handling Unit Control:
 - .1 Humidity Control: The humidity PID loop shall open and close three solenoid valves in rotating sequence to ensure even CELDEK usage. The controlling variable shall be the return air humidity. The return humidity set point shall be a fixed user adjustable value initially set at 20%RH. Provide high and low limits.
 - .2 Alarm Monitoring: Provide the following alarms as a minimum:
 - Low temperature switch
 - High supply duct static pressure
 - Fan drive status (off/hand/auto)
 - Low mixed air plenum static pressure
- .5 Heating Pumps
 - .1 If any of the primary heating water circulating pumps fails to start after 60 seconds of the start command a pump failure alarm shall be annunciated at the BMS and the next primary heating water circulating pump shall be commanded to start.
- .6 Radiation System
 - .1 Provide start/stop control through the BMS. The radiation/terminal units supply pump shall be controlled based on a constant volume supply with a temperature control valve at the inlet. The control valve function shall modulate to mix the radiation supply at a pre-set temperature lower than the main heating supply temperature.
 - .2 The duty heating pump speed shall be controlled through a variable frequency drive to maintain the pressure differential between the heating distribution supply and return

mains. The set point shall be initially set at 75kPa and adjusted during commissioning based on the measured data obtained from the water balancing procedure.

- .3 The two-way control valve shall be modulated to maintain the heating water supply temperature set point.
- .4 The heating water supply temperature set point shall be adjusted with outdoor air temperature based on the following schedule: at 10° C outside air temperature the heating water supply temperature set point shall be 54° C. At -20° C outdoor temperature the heating water supply temperature set point shall be 75° C.
- .7 Condenser Water System:
 - .1 The cooling tower packaged controls shall modulate the fan speed and modulate capacity control dampers to maintain the condenser water supply temperature set point.
 - .2 The cooling tower sump level shall be maintained by the cooling tower packaged level controller. Sump Heater shall be used to maintain sump temperature above 5° C.
- .8 Primary Chilled Water:
 - .1 Chillers shall be manually enabled/disabled through the BMS.
 - .2 When a chiller is enabled through the BMS, the primary chilled water return isolation valve shall open and the distribution pump shall start.
 - .3 Chiller will start when chilled water and condenser water flow is confirmed by the chiller's packaged controller.
 - .4 Chilled water supply temperature will be maintained at a BMS set point by the chiller's packaged controlled.
- .9 Supply Air Terminal Units:
 - .1 Each terminal shall control the perimeter heating control valve reheat coil valve and the damper actuator with PID loop control.
 - .2 The damper's actuator shall modulate to maintain the terminal unit's constant volume airflow set point.
 - .3 The reheat coil valve and perimeter heating control valve shall modulate in sequence to maintain the room temperature set point.
 - .4 The setback temperature shall set the room temperature back for unoccupied hours. The perimeter heating control valve shall be modulated to maintain room setback temperature set point.
 - .5 Shall be available to view the following points from the BMS for all supply air terminal units:

- Room temperature
 - Heating/cooling mode
 - Room temperature set point
 - Air flow
 - Damper position
 - Heating valve position (reheat and radiation)
 - Time Scheduling and/or Occupancy Sensors (if requested)
- .10 Cabinet Unit Heaters and Unit Heaters:
- .1 Unit heater fan shall be cycled on when the line voltage thermostat falls below set point. Temperature sensors for standard unit heaters are not required to be tied into the BMS unless approved by the University.
 - .2 When the fan is cycled on, the line voltage solenoid isolation valve shall be opened.
- .11 Exhaust Fan Control:
- .1 When an exhaust fan is commanded on, the damper shall first be opened. When the damper end switch confirms the position, the fan shall be started.
 - .2 Provide a fan status at the BMS for each fan.
 - .3 Provide a fan failure alarm at the BMS for each fan.

26 00 00 ELECTRICAL

26 06 00 Schedules for Electrical

- .1 General wiring devices shall be specification grade. Emergency receptacles shall be in red with isolated ground receptacles in orange. The building standard receptacle is duplex, specification grade NEMA 5-15R and housekeeping receptacle be duplex, specification grade NEMA 5-20RA. Housekeeping receptacles shall be in exterior walls and walls around primary corridors.

26 08 00 High Voltage Electrical Distribution (15kv)

- .1 Cable size to be minimum 2/0
- .2 Coordination study required if/when new switches are added to the U of L 15kv distribution

26 08 05 Equipment Manufacturer:

- .1 S & C
- .2 Switches to be “dead front”.

26 08 07 Underground Duct Banks

- .1 Duct banks to be concrete encased.

- .2 Minimum of two (2) extra ducts included.
- .3 25 mm conduit to be included in duct bank.
- .4 Duct bank to be buried 1 meter under finished grade.
- .5 Warning ribbon to be installed 30mm above top of duct bank.
- .6 Manhole covers serving electrical duct banks are to have 'ELECTRICAL' cast in cover.
- .7 Manhole covers serving telecom/IT duct banks are to have 'TELECOM' cast in cover.

26 08 10 *Medium-Voltage Electrical Distribution (347/600v)*

- .1 Each feed into any campus building/structure to be metered.
- .2 Electrical distribution to contain infrared windows for thermography.
- .3 Provide one meter clearance to allow access to equipment.
- .4 Neutrals to be labeled with associated circuit number at the panel.
- .5 Conductors to be identified as orange/brown/yellow.
- .6 No aluminum conductors.
- .7 Cables to be installed without splices.
- .8 Main service metering; Ion 7350.
- .9 Coordination study in O & M manual with breaker trip settings.

26 15 00 **Low-Voltage Electrical Distribution (120/208v)**

- .1 The main distribution panel shall have an amp meter, voltmeter, kWh meter, amp and volt switches.
- .2 Distribution systems to use copper wiring.
- .3 Electrical distribution to contain infrared windows for thermography.
- .4 A maximum of 20-amp circuits shall be provided for lighting.
- .5 Housekeeping to be T-slot 20-amp receptacles.
- .6 All lighting and power circuits shall be kept separate from each other, with dedicated separate lighting and power panels, unless otherwise approved by the University.

- .7 When replacing low voltage switches in existing areas, the contractor shall replace the low voltage switch with the same manufacturer as the existing unit. For new installations see the acceptable manufacturer's list for further details.
- .8 Minimum 12 awg copper conductors.
- .9 No aluminum conductors.
- .10 Neutrals to be labeled with associated circuit number at the panel.
- .11 Provide one meter clearance for access to equipment.
- .12 Cables to be installed without splices.
- .13 All mechanical rooms to be equipped with a welding outlet.
- .14 Power and lighting systems are not to share the same circuit.

26 20 00 **ARC Flash Study and labeling**

- .1 Provide ARC flash study.
- .2 Supply and install ARC flash labeling:
 - .1 Labels to have a 12mm green border for ratings 1.2 cal. or less.
 - .2 Labels to have a 12mm yellow border for ratings of 1.2001 to 10 cal.
 - .3 Labels to have a 12mm red border for ratings of 10.001 to 50 cal.
 - .4 Labels to have a 12mm black border for ratings greater than 50 cal.
- .3 Consult with University Electrical Department to determine label locations.

26 22 00 **Transformers (15Kv to 600 or 208)**

- .1 All Transformers to be of copper windings.
- .2 Acceptable transformer manufacturers:
 - .1 Carte
 - .2 Pioneer Transformers LTD
 - .3 Partner Technologies LTD
 - .4 Hammond

26 22 01 *Dry-Type, Medium-Voltage Transformers*

- .1 Transformers shall be mounted on isolators to minimize transmission of vibration noise to building structure.

26 24 00 Switchboards and Panelboards

26 24 01 Panel boards

- .1 The main distribution panels shall have one main breaker.
- .2 Size to provide minimum 25% future growth.
- .3 Supply 2,15A and 2, 20A spare breakers.
- .4 All panelboards shall be bolt on style.
- .5 Panelboards shall have an isolated neutral bus and a ground bus bonded to the cabinet.
- .6 Green ground wire shall be installed with all circuits.
- .7 Panelboards shall have surge protection.

26 24 02 Motor-Control Centers

- .1 Structures shall be totally enclosed, dead front, free standing.
- .2 Guide rails for control units, accessible wireways, and terminal blocks for control wiring shall be provided.
- .3 Starters shall be of the combination type with circuit breakers. Each starter shall have two normally open and two normally closed auxiliary contacts wired to the terminal blocks, hand-off-auto switch, red light indicates energized or on and green light indicates not energized or off.
- .4 Starters shall be wired so that at the loss of electrical power they revert to automatic operation when power is restored.
- .5 The motor control centre shall be sized for a minimum 25% spare capacity.
- .6 MCC shall be complete with bus bar, rails, wire ways and other appurtenances so that no additional hardware is required for future expansion.

26 29 00 Motor Controllers

26 29 01 Across-the-Line Motor Controllers

- .1 Controlled by BMS unless indicated differently.

26 29 05 Soft Start Controllers

- .1 Controlled by BMS unless indicated differently.

26 29 10 *Variable-Frequency Motor Controllers*

- .1 Controlled by Building Management System (BMS) unless noted otherwise.
- .2 All drives shall be equipped with the following features:
 - .1 A DC link line reactor of sufficient impedance (5%) to protect the drive, and limit harmonics.
 - .2 Output filter.
 - .3 Fault shutdown and indication.
 - .4 Automatic restart following power outage.
 - .5 Ability to disconnect motor load for setup, repair or maintenance.
 - .6 Supply three spare fuses per drive, to be turned over to the University electrical department.
 - .7 Adjustable maximum and minimum speed.
 - .8 Acceleration and deceleration time adjustment.
 - .9 Controller “stop” interlock from an NC dry contact.
 - .10 Drive fault contact.
 - .11 Stop/Start push buttons on keypad.
 - .12 Electro-mechanically controlled bypass (bypass contactor)
 - .13 Three dry “C” type contacts programmable for any combination of the following:
 - Running
 - Fault lockout
 - Stopped
 - At speed
 - Under speed
 - Forward/Reverse
 - Low reference
 - Manual/Auto Mode
 - Local/Remote Mode
 - Lon Works
 - .14 Soft Start sequence.
 - .15 Regenerative braking.

- .16 Minimum of three skip frequencies.
- .17 Output speed monitoring signal to be selective between 4-20 mA or 0-10 Volt.
- .18 Door interlock fused disconnect switch, lockable in the off position.
- .19 Supply one set (three) of fuses.
- .3 VFD's shall be mounted as close to the motor as possible.
- .4 All VFD's shall be commissioned by a factory representative with supporting documentation to the University. The factory representative is to fully calibrate and verify all drive circuits after installation to on site equipment.
- .5 Provide a minimum of an 18 month parts and labour warranty from the date shipped and a 12-month parts and labour warranty from the startup date for all VFD's.
- .6 Cable running from the VFD to the motor shall be a VFD rated cable. Cabling shall have a PVC jacket over an aluminum sheath and contain three phase conductors and three ground conductors.
- .7 VFD's shall have a factory installed BACnet or LonWorks communication card depending on which system is being used. Consult with U of L to specify.
- .8 Acceptable Manufacturer: Danfoss.

26 29 15 *Motors*

- .1 All motors shall be high – efficiency type, (VFD rated).
- .2 Acceptable motor manufacturers:
 - Teco Westinghouse
 - US Motors
 - Lesson
 - Siemens
 - Reliance Electric
 - GE Canada

26 30 00 **Facility Electrical Power Generating**

- .1 Existing buildings shall only have loads connected to the emergency power system as required by the governing codes and as approved by the University
- .2 Equipment in new structures such as fire alarm systems, emergency lighting and security panels shall be provided with an emergency backup power supply. All other equipment shall be identified on a case-by-case basis.

26 50 00 Lighting

- .1 If new permanent light fixtures are used during construction and exceed 10% of rated life, all lamps to be replaced with new at project end.
- .2 All ballasts will have disconnected regardless of voltage.
- .3 Lighting systems are to not be combined with power circuits.

26 51 00 Interior Lighting

- .1 No incandescent.
- .2 Match voltage of lighting to existing building lighting.
- .3 Lamps shall be T8, T5, compact fluorescent, LED or better. Use of lamp types will require review from the University Electrical Department.
- .4 Lamps shall be 841 Fluorescent lamps shall have a colour temperature of 4100K, have a CRI > 85 and contain low levels of mercury. LED lamps shall have a colour temperature of 4000K with a CRI > 80. Acceptable manufacturers for lamps are Philips Advance, Osram Sylvania, Standard, and GE.
- .5 All fluorescent ballasts shall be electronic. Ballasts shall be instant start or program start with less than 10% THD (total harmonic distortion) and be CSA certified and ULC listed.
- .6 LED drivers to have a power factor greater than 0.90, and less than 20% THD (total harmonic distortion),
- .7 All core and coil HID ballasts shall have a nominal ballast factor of 1.0, Capacitors rated at 400 volts or less shall be dry film type with no exposed live parts. Igniters shall have a temperature rated case of 105 C with no exposed live parts.
- .8 All electronic HID ballasts shall have a power factor greater than 90%, less than 15% THD (total harmonic distortion), and be sound rated A.
- .9 Daylighting shall be reviewed for all applications and fully used.
- .10 Maximum 1.2 meter of flexible conduit to luminaire.
- .11 New building interior lighting to be 120 volts.
- .12 13 mm conduit acceptable for secondary runs from main/home runs.
- .13 When low voltage lighting control is used Douglas lighting control is the acceptable manufacturer, Low voltage lighting panels are to be networked together using WNX 2624 network card that attaches to the bottom of the WRS 2224 relay scanner. An 8471 Belden or equivalent cable shall be used when connecting the panels together to expand the network. If a

new network is created a WNP 2150 network manager is required. All motion sensors shall be pulled back the Douglas panel. WR 6161 relays are used with this application. New Douglas panels shall be programmed by Douglas to allow lighting panel network unification.

- .14 Motion sensor preferred manufacturer; Wattstopper. Sensors should use infrared and ultrasonic technology (dual technology).
- .15 All ballasts will have disconnects regardless of voltage.
- .16 All interior lighting used in new building construction to be 120 volts.
- .17 Neutral wires shall be labeled with the circuit numbers that they serve in all electrical panels.
- .18 Building lighting should be used to highlight building entrances and architectural elements and consider the effects of glare and the impact of overall energy use and maintenance.

26 52 00 **Safety Lighting**

- .1 For new buildings, 'Nexus' systems are preferred.
- .2 For other installations, utilize Table 26 05 00-1.

26 52 13 *Emergency Lighting*

- .1 Supplemental battery powered emergency lighting is recommended to be installed to bridge the generator start-up time delay in all generator rooms, main electrical rooms and Automatic Transfer Switch (ATS) rooms for buildings where ATS is not located in the generator room. Battery packs will not be used in buildings that are supported by an emergency generator except for the areas above.

26 56 00 **Exterior Lighting**

- .1 All outdoor lighting to be controlled by BMS through a contactor or Douglas lighting system, complete with a manual override switch. As applicable, photocells shall be placed to provide optimum energy use and for security considerations.
- .2 If photocells are required, shall be placed to provide optimum turn on time for security considerations.
- .3 If applicable exterior lighting shall be base mounted ballasts if pole is taller than 5 meters.
- .4 Preferred lighting to be LED at a colour of 4,100k.
- .5 No HPS.
 - .6 All exterior lamps shall be base mounted ballasts (as applicable) and consider energy efficiency, efficacy, environmental effects of light pollution, colour index (+/- 4,100k) and be LED or Metal Halide.

27 00 00 COMMUNICATIONS

27 00 01 General Introduction

- .1 This standards document is to be used for any projects on the University of Lethbridge campus that involves the voice and data distribution system or the facilities that house them. It is designed not only to provide the standard implementation system to be used on campus but also provides guidance regarding engagement of the University of Lethbridge Information Technology Services (IT Services) for projects.

This section of the standards document provides information on the U of L IT Services cabling practices, standards, and components. All cabling projects are required to follow these standards and practices to ensure that the University structured cabling systems can support new applications that require higher speeds and increased reliability.

- .2 Information Technology Services can examine how individual projects interact with existing and future infrastructure & equipment requirements to help specify integrated solutions. IT Services, in conjunction with Facilities and Campus Development, will determine the best solution for each project.
- .3 Standards outlined here follow the EIA, TIA, and CSA standards for commercial buildings and BICSI best practice recommendations
 - .1 Design, manufacture, test, and install data distribution systems per manufacturer's requirements and in accordance with NFPA 70 (National Electric Code), state codes, local codes, requirements of authorities having jurisdiction, and particularly the following specifications.
 - .2 This Technical Specification and Associated Drawings
 - .3 ANSI/TIA-568-C.0, Generic Telecommunications Cabling for Customer Premises, and its published addenda.
 - .4 ANSI/TIA-568-C.1, Commercial Building Telecommunications Cabling Standard, and its published addenda.
 - .5 ANSI/TIA-568-C.2, Copper Cabling Components Standard, and its published addenda.
 - .6 ANSI/TIA-568-C.3, Optical Fibre Cabling Components Standard, and its published addenda.
 - .7 ANSI/TIA/EIA-569-B, Commercial Building Standard for Telecommunications Pathways and Spaces, and its published addenda
 - .8 ANSI/TIA/EIA-606-B, Administration Standard for the Telecommunications Infrastructure of Commercial Buildings, and its published addenda
 - .9 ANSI/J-STD-607-B, Commercial Building Grounding (Earthing) and Bonding Requirements for Telecommunications, and its published addenda.
 - .10 Building Industries Consulting Services International (BICSI) Telecommunications Distribution Methods Manual (TDMM)
 - .11 TE Connectivity Design and Installation Contractor Agreement
 - .12 ANSI/TIA-942, Telecommunications Infrastructure Standard for Data Centres, and its published addenda.
 - .13 Determine and adhere to the most recent edition of these specifications when developing responses.
- .4 Relevant national and/or provincial electrical codes are always to be followed.

27 05 00 Common Work Results for Communications

27 05 13 Communications Services

.1 IT Services - Telecom Project Involvement

While University standards will be followed in all cases, the unique nature of every project requires IT Services input on all projects that involve voice, data, or wireless. IT Services is to be consulted for the following:

- .1 Design or design review of Voice, Data, and Wireless systems
- .2 Copper cable manufacturer selection for new buildings and large-scale renovations.
- .3 Fibre cable manufacturer selection for new buildings and large-scale renovations.
- .4 Demolition of existing telecommunications infrastructure
- .5 Construction of telecommunications infrastructure
- .6 Commissioning of telecommunications infrastructure

.2 Project Management

Project Managers are to engage with IT Services at appropriate points in all major or significant projects as indicated below.

- .1 Initial project design and preliminary equipment budgeting.
- .2 Participate in design and site meetings.
- .3 IT Services will examine how projects interact with existing and future infrastructure & equipment requirements to help specify the best campus solution.
- .4 All IT Services costs, as determined by IT Services, are to be included in the project budget.
- .5 Project Managers need to provide as-built drawings for risers and cabling systems.
- .6 If project designs are more than a year old they should be re-evaluated by IT Services to ensure they meet current standards and components.

.3 Contractor Requirements

- .1 As required by IT Services, contractors may be required to attend an orientation session with IT Services regarding structured cabling.
- .2 Contractors are required to be manufacturer-certified in the cabling solution being installed for any given project.

27 08 00 Commissioning of Communications

.1 Project sign off by IT Services is to occur at the following project stages

- .1 Specification preparation
- .2 60 and 90% stage construction drawings
- .3 Change orders
- .4 Completion

27 11 00 Communications Equipment Room Fittings

- .1 The primary communications room of the building should be located close to the building service entrance or utility ingress to the building.

- .2 The room size is dictated by the number of cabinets required in the room and the unobstructed clearance required around the cabinets and back wall. Room size requirements shall be based on the square footage of the area being serviced so that future growth can be accommodated without substantial redesign. The table and diagrams below will be used to determine minimum required sizes. Riser's servicing multiple floors may need to be larger. It should be noted that typical requirements will be based on floor space and not initial space utilization due to the very high costs of adding additional capacity later.
- .3 The building communications room shall be planned exclusively for telecommunications support. Avoid any building power or water distribution equipment for Facilities in the same room.
- .4 The floor of the communications rooms shall, at minimum, be sealed to reduce dust. Door seals or sweeps are preferred to reduce the collection of dust and debris in the communications room.
- .5 While sizing will have to be adjusted to suit individual requirements, we recommend that the main communications room be a minimum of 3 m x 6 m unobstructed by door swing. See 27 11 27 for typical room layout and sizing information.
- .6 Communications riser rooms shall be vertically aligned with the primary communications room's riser facilities. In cases where more than one riser stack is required, cable tray shall be provided from the communications rooms to each remote riser system. Where risers cannot be vertically aligned, three (3) 100mm ducts shall be provided between communication rooms.
- .7 Three (3) 1,200 mm x 2,400 mm sheets of 20 mm G1S plywood shall be mounted, with their longest edge vertical, on the 4m wall noted above. The sheets shall be mounted directly to the wall and painted with fire retardant paint to match the surrounding area.
- .8 Adequate light to allow technicians to work on communications support equipment shall be provided.
- .9 Adequate ventilation must be designed and installed to carry the projected heat load for all active networking equipment located within the room.
- .10 There shall be a minimum of 2,400 mm of clearance between the working floor and the lowest ceiling-mounted fixtures (lights, cable-trays, etc.).
- .11 Any plywood mounted within the room shall be painted with fire retardant paint.

27 11 13 Communications Entrance Protection

- .1 Communications room doors must, at least, be provided with locks that are keyed to Maintenance and Operations Standards. Depending on the importance of the communications facilities to the occupants, the benefits and costs of a security alarm system should be carefully evaluated.

27 11 16 Communications Cabinets, Racks, Frames, and Enclosures

- .1 The equipment located in the room will be generating heat. While precise environmental control requirements, if any, cannot be generalized without specific knowledge of equipment requirements, air circulation through the room is required at minimum. The target room

temperature shall be 18 C to 24 C (64 F to 75 F). Designers shall keep in mind the fact that many building air handling systems deliver heat during the cold months, and special treatment of the communications room may be required.

- .2 One (1) four post rack (minimum 32" depth - for network equipment), along with one (1) or more 19" two post telco racks will be required, depending on the service area of the communications room. This will be evaluated by IT Services during the design phase of the project.
- .3 Vertical cable management units must be installed between racks, with a 6" cable management unit on both the left and right sides of the four-post rack and a 6" cable management units between subsequent racks. See room diagrams for details.
- .4 Horizontal cable management units must be installed in all racks between every 2 network devices or every two patch panels.

27 11 19 Communications Termination Blocks and Patch Panels

- .1 Patch panels for data cabling shall be terminated on the two-post telco rack with 24 ports of data per 1U rack space. There shall be a 2U horizontal cable management unit placed before and after every 2 patch panels.
- .2 Termination blocks for analog cabling shall be located on the back wall of the telecom room affixed to the backing board.

27 11 23 Communications Cable Management and Ladder Rack

- .1 A minimum of three (3) 100 mm ducts or a 300 mm x 100 mm tray is required from the service entrance of the building to the communications room. The duct/tray shall originate to the existing low voltage tray in the service tunnel and terminate at the backboard. Sweep 90 degree bends are to be installed to facilitate pulling of PIC-S backbone cable, home run data cables, and fibre-optic cable.
- .2 Under normal circumstances, three (3) 100 mm conduit sleeves per riser room shall be provided for passage between floors. In general, one sleeve will be used primarily for voice cabling, one sleeve will be used primarily for data cabling, and the third sleeve will allow for quick and inexpensive growth and change. Note that the recommendation is for short sleeves between floors and not for continuous conduit and that these sleeves must be equipped with removable fire stops. In general, we have found sleeves to be much easier to work with than slots or other facilities. All sleeves must be bonded to the building ground system. All sleeves shall have conduit extending 5cm above the floor slab to prevent water damage in the event of a flood.
- .3 For buildings with certain types of communications requirements, the rule of three (3) conduit sleeves per riser room per floor would possibly change. Such changes will be stipulated by IT Services during the design phase.
- .4 For buildings with more than one (1) riser system, facilities shall be provided to support cable runs between the riser rooms on each floor, as will be detailed in the section on horizontal distribution systems below. These facilities must be separate from the horizontal distribution systems specified for the voice/data outlet wiring, i.e., riser cables must be kept separate from all other cables.

- .5 All cable-trays shall be brought to the vicinity of one of the 6m walls without a door. Risers and all other cable-trays shall be located in the vicinity of the same wall.

27 11 26 *Communications Rack Mounted Power Protection and Power Strips*

- .1 A minimum of four (4) dedicated 120 VAC single-phase (20) ampere circuits shall be placed evenly in the cabinets with quad-outlet boxes. Emergency power and UPS shall be included for these and any communications riser room circuits on the system. Other outlets may be required depending on the actual equipment to be in the room.
- .2 The communications room must have its own earth ground brought to the backboard noted. This ground must not be in common with building electrical grounds and shall join all communications riser grounds only at the building ground point. The ground is used for sensitive equipment, not for bonding conduit and tray systems. A minimum of #6 copper wire shall be used unless codes call for larger wire. The ground is to terminate on a solid copper ground bar (50 mm x 260 mm x 5.6 mm) bent to have a 20 mm standoff.
- .3 All communication racks to be grounded to the main grounding bar individually.

27 11 27 *Room Diagrams*

Diagram 27 11 27 – 1 *Dual Rack Room*

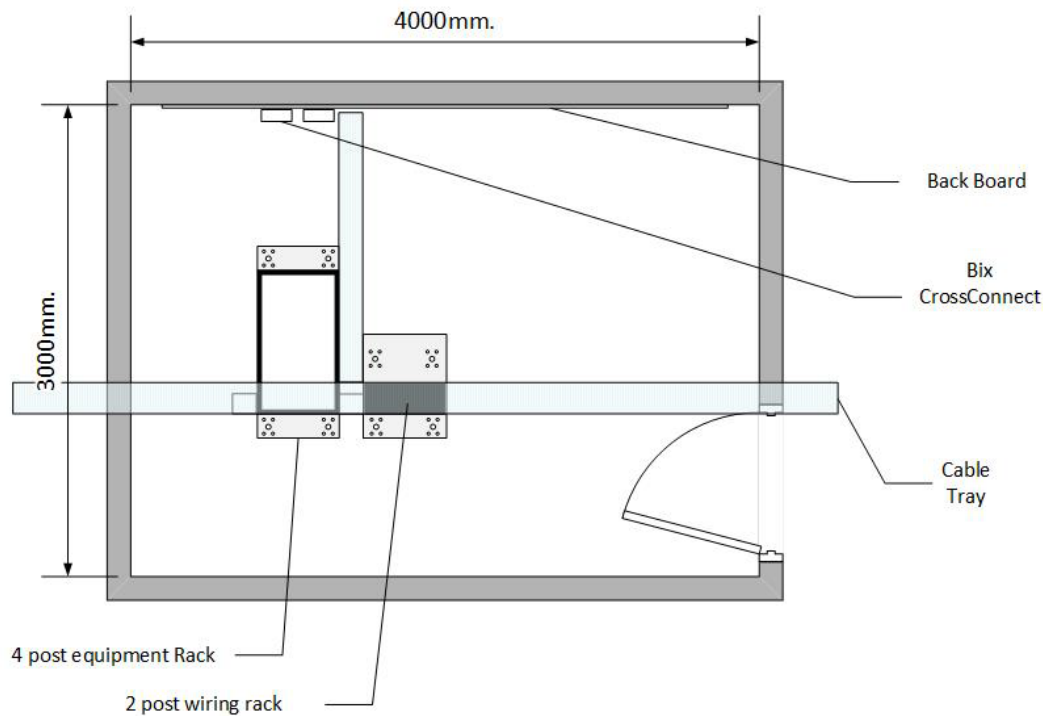

Diagram 27 11 27 – 2 Triple Rack Room

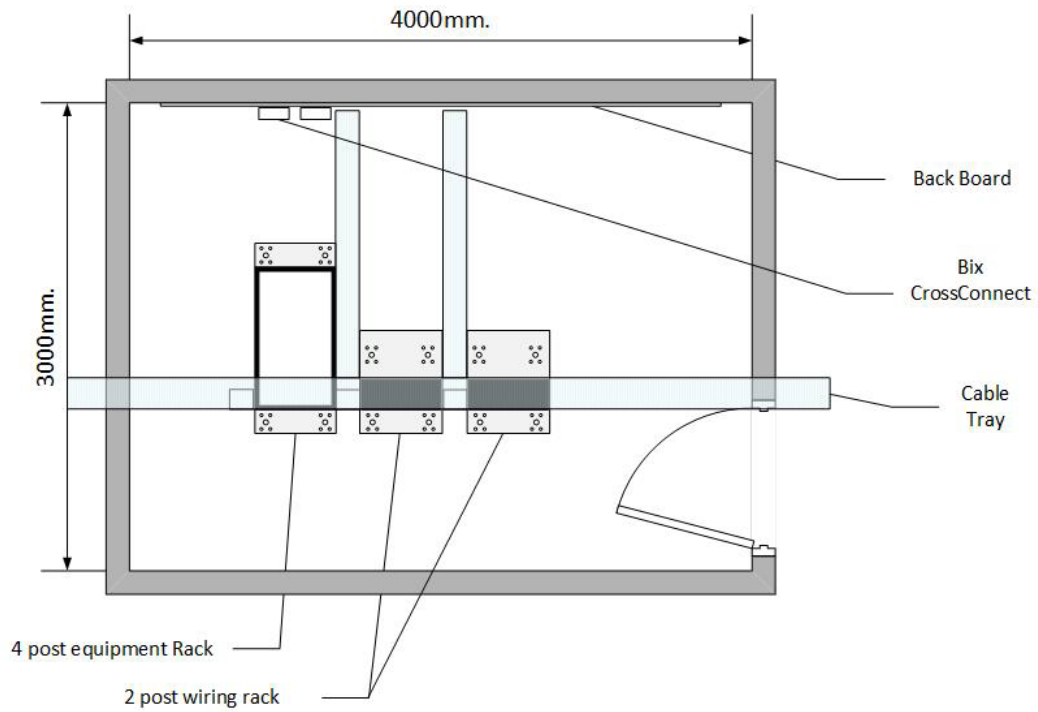

Diagram 27 11 27 – 3 Quad Rack Room

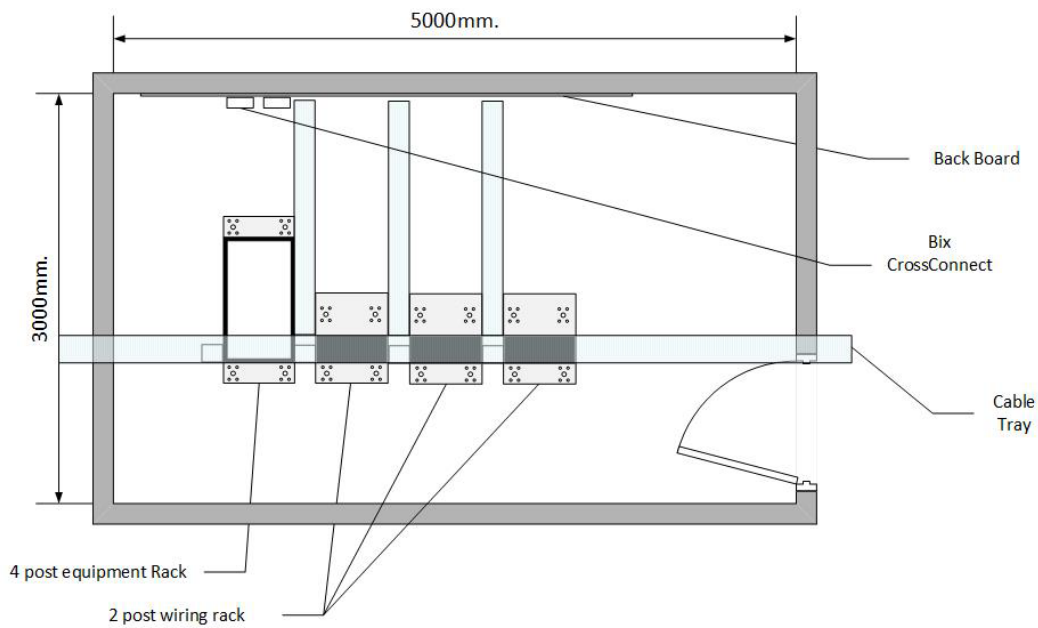
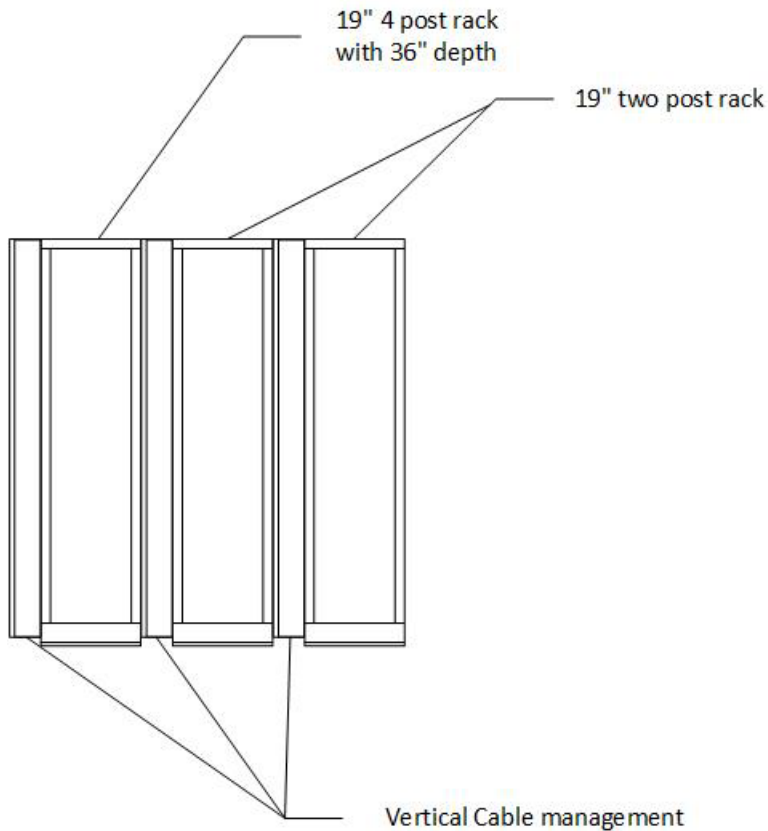

Diagram 27 11 27 – 4 *Rack Front View*



27 13 00 Communications Backbone Cabling

27 13 13 Communications Copper Backbone Cabling

27 13 13.13 Communications Copper Cable Splicing and Terminations

- .1 Bonding - In all cases where pairs enter or leave the cable sheath, the cable shield must be bonded to the ground bus bar using #6 AWG copper wire.

27 13 23 Communications Optical Fiber Backbone Cabling

The University of Lethbridge has standardized the following fibre types for all in building and campus backbone fibre panel products. Cabling will be specified for each project depending on requirements.

- .1 For any backbone applications, provide redundant routes for fibre. For riser applications, redundant routes should be considered where possible.
- .2 Armor jacketed Single Mode fibre will be required in all outside plant (OSP) installations.
- .3 multi-Mode OM-3 fibre shall be installed in any inside plant (ISP) locations less than 300m in length and Single Mode fibre shall be install if distances are over 300m.

- .4 All fibre terminations shall be LC connectors.
- .5 Acceptable manufacturer products will be determined on a case-by-case basis, in conjunction with UofL IT Services. Acceptable manufacturers are:
 - .1 Commscope AMP/Netconnect
 - .2 Corning
 - .3 Superior Essex
- .6 Testing procedures for fibre optic cables:
 - .1 After cable delivery (still on reel) the contractor or manufacturer shall test each fibre strand for attenuation at 1300 nm for multi-Mode fibre and 1550 nm for Single-Mode fibre using an Optical Time domain Reflectometer (O.T.D.R.). The contractor shall provide a written report (with digital copy) of the test results to IT Services. The University of Lethbridge must approve format of soft copy. The report must identify which fibre corresponds with the respective test measurement data supplied, so IT Services technical personnel can verify the results before installation begins.
 - .2 During and upon completion of a fibre cable installation IT Services technical personnel reserve the right to inspect and test the cables at any time to ensure proper installation and testing procedures are being followed.
 - .3 O.T.D.R. tests are to be conducted upon completion of a fibre installation and are to be conducted from both directions.
 - .4 Attenuation is to be measured end to end. Nominal operating wavelengths of 850 nm and 1300 nm for multi-mode fibre and 1550 nm for Single-Mode fibre are to be verified and specified in decibels (dB) on acceptance documents approved by IT Services.
 - .5 Visual hard copy records (print of O.T.D.R. Data trace, signed off) of fibre, splice, and/or connectors are required. These records are also to be provided in soft format approved by IT Services.
 - .6 Distances to localized attenuation, splices, connectors and fibre ends are to be measured on the O.T.D.R. documented on acceptance documents providing information for system maintenance and trouble shooting.
 - .7 O.T.D.R. graphs are to be submitted to IT Services. One signed off set of these graphs is required. Records are also to be submitted electronically via digital copy.
 - .8 The cable shall meet or exceed the requirements of the specifications for fibre dimensions, attenuation, band width, numerical aperture, fireproof test, cable bending, tensile load, impact resistance, crush resistance, and attenuation versus temperature.

27 15 00 Communications Horizontal Cabling

27 15 01 Communications Horizontal Cabling Applications

27 15 01.16 Voice Communications Horizontal Cabling

The University of Lethbridge has standardized on the NORDX/CDT BIX telephony cross connect system across the campus. Cabling will be specified for each project depending on requirements.

- .1 Backbone and riser cables are to be NORDX/CDT twenty-four (24) AWG ARMM/ATMM multi-conductor that conforms to CSA Standard T529-M91, Section 10.3.1, or a compatible product approved by IT Services.
- .2 Enclosures are to be NORDX/CDT Bix Frame (2,4, or 10 position as appropriate), or a compatible product approved by IT Services.
- .3 Terminations are to be NORDX/CDT Bix1A, or a compatible product approved by IT Services.
- .4 Acceptable products are listed in Appendix B – Parts and Components.
- .5 Typical 200 pair required to building entrance, terminated on Circa Building Entrance terminal 2100SB-100, or a compatible product approved by IT Services.
- .6 Typical 25 or 50 pair to each riser closet, as determined by IT Services.
- .7 Testing procedures:
 - .1 Backbone and riser cable: Perform the following tests on the backbone and riser cables:
 - Continuity and polarity test for each pair
 - dB loss of white, blue pair of each binder group
 - Length of white, blue pair of each binder group
 - .2 A digital copy of all test results shall be provided to IT Services.

27 15 01.49 Intermediate Frequency/Radio Frequency Communications Horizontal Cabling

- .1 The UofL wireless system must be installed in all new buildings and major renovations.
 - .1 IT Services will produce required wireless designs for all projects and will consult with the project teams to determine access point (AP) locations.
- .2 Generally for 802.11a/b/g/n/AC, one AP is installed for every 1200 square feet. Usage density, floor plans, and obstructions all influence AP placement so IT Services will provide placement recommendations based on blueprints and site surveys if required.
- .3 Certain types of research or other activities may produce radio interference with 802.11a/b/g/n/AC wireless devices. Any anticipated radio interference sources shall be discussed with IT Services during the design development phase.

27 15 01.53 Antennas Communications Horizontal Cabling

- .1 While most of the wireless equipment has integral antennas, there are situations where this is not practical and external antennas will be required. IT Services shall be consulted on all external/remote antenna cabling and placement.

27 15 13 Communications Copper Horizontal Cabling

The University of Lethbridge follows the TIA/EIA-568-B cabling standards with T568B pin pair assignments. Each project must be evaluated to determine the copper station cabling to be used. Standard practice is shown below.

- .1 New buildings or major renovations, at IT Services discretion, will be required to have Category 6A copper cabling solutions.
- .2 Acceptable cabling and components for CAT6A will be end-to-end solutions provided by one of the following approved vendors and products and shall carry a manufacturer warranty of a minimum of 25 years on the end-to-end solution and installation.
 - .1 Commscope AMP/NetConnect (formerly Tyco Electronics)
 - .2 Commscope SystiMax
 - .3 Belden REVConnect
 - .4 Siemon Z-MAX
 - .5 Note that the UofL is currently AMP/NetConnect certified to support our existing cabling infrastructure. If an AMP/NetConnect solution is not used, training and certification for UofL staff must be included in the solution to allow continuation of the above manufacturer warranty.
- .3 Projects in existing buildings will have to be evaluated by IT Services individually to see if cable plant renewal is required. If cable plant renewal is not required, cabling shall be installed following the current cabling standards of the location.
- .4 Colour standards for data cabling is as follows:
 - .1 Blue Standard Data
 - .2 White Analog Voice
 - .3 Yellow Wireless
 - .4 Red Security (CCTV)
 - .5 Purple Building Management Systems
 - .6 Black Special Purpose
- .5 Patch cables for station connectivity and communication room equipment are to be included in the project scope and left on site in the communications room for deployment. Required are

- one (1) each of 2 meter and 3-meter Cat6A, non-boot, snag less, colored the same as the above cabling color standards.
- .6 Typical two (2) cables per workspace or office location. If spaces warrant, one pair of cables on each side of the space.
 - .1 If conduit is to be installed, each outlet requires its own run of conduit (no daisy-chaining) either to the main cabling pathway, or directly back to the main communications room.
 - .7 Classroom locations will require three (3) network drops to the central podium location.
 - .8 Wireless Access Point drops will require two (2) cables per location, terminated above ceiling tiles where possible. IT Services shall be consulted regarding locations where above ceiling tile is not possible.
 - .9 CCTV camera drops will require one (1) cable per location, terminated inside of the camera mount box except where an additional drop is required as determined by IT Services.
 - .10 An end-to-end solution provided through the project including all required patch cables.
 - .11 All outdoor copper will be required to utilize shielded, armored cabling, and is to be installed in underground conduit. Category of cabling (Cat5E or Cat6A) will be dependent on circumstance and will be determined by IT Services.
 - .1 Outdoor cable type is to be Belden 7937A or equivalent.
 - .12 Labeling (as per EIA/TIA 606A standards). Labeling processes are reviewed in the IT Services orientation for contractors and include the following.
 - .1 Building/Floor/Riser/Patch Panel/Port Jack location (ie. E556-2, TH314-4, etc.).
 - .2 Patch Panel to identify Building/Floor/Riser/Patch Panel/Port Jack location of room (ie, E556-2, TH314-4, etc.)
 - .13 Testing of Horizontal Cabling
 - .1 Each drop shall be channel tested to meet the transmission performance specifications for the category of cable system being installed.
 - .2 A digital copy of all test results shall be provided to IT Services

27 15 23

Communications Optical Fiber Horizontal Cabling

The University of Lethbridge has standardized the following fibre types for all in building and campus backbone fibre panel products. Cabling will be specified for each project depending on requirements.

- .1 For any backbone applications, provide redundant routes for fibre. For riser applications, redundant routes should be considered where possible.
- .2 Armor jacketed Single Mode fibre will be required in all outside plant (OSP) installations.
- .3 multi-Mode OM-3 fibre shall be installed in any inside plant (ISP) locations less than 300m in length and Single Mode fibre shall be install if distances are over 300m.
- .4 All fibre terminations shall be LC connectors.
- .5 Acceptable manufacturer products will be determined on a case-by-case basis, in conjunction with IT Services. Acceptable manufacturers are:
 - .1 Commscope AMP/Netconnect
 - .2 Corning
 - .3 Superior Essex
- .6 Testing procedures for fibre optic cables:
 - .1 After cable delivery (still on reel) the contractor or manufacturer shall test each fibre strand for attenuation at 1300 nm for multi-Mode fibre and 1550 nm for Single-Mode fibre using an Optical Time domain Reflectometer (O.T.D.R.). The contractor shall provide a written report (with digital copy) of the test results to IT Services. IT Services must approve format of soft copy. The report must identify which fibre corresponds with the respective test measurement data supplied, so IT Services technical personnel can verify the results before installation begins.
 - .2 During and upon completion of a fibre cable installation IT Services technical personnel reserve the right to inspect and test the cables at any time to ensure proper installation and testing procedures are being adhered to.
 - .3 O.T.D.R. tests are to be conducted upon completion of a fibre installation and are to be conducted from both directions.
 - .4 Attenuation is to be measured end to end. Nominal operating wavelengths of 850 nm and 1300 nm for multi-mode fibre and 1550 nm for Single-Mode fibre are to be verified and specified in decibels (dB) on acceptance documents approved by IT Services.
 - .5 Visual hard copy records (print of O.T.D.R. Data trace, signed off) of fibre, splice, and/or connectors are required. These records are also to be provided in soft format approved by IT Services.
 - .6 Distances to localized attenuation, splices, connectors and fibre ends are to be measured on the O.T.D.R. documented on acceptance documents providing information for system maintenance and trouble shooting.

- .7 O.T.D.R. graphs are to be submitted to IT Services. One signed off set of these graphs is required. Records are also to be submitted electronically via digital copy.
- .8 The cable shall meet or exceed the requirements of the specifications for fibre dimensions, attenuation, band width, numerical aperture, fireproof test, cable bending, tensile load, impact resistance, crush resistance, and attenuation versus temperature.

27 21 00 Data Communications Network Equipment

- .1 Every project must conform to the University of Lethbridge's current standards for network equipment and device configuration. These standards apply to all the following:
 - .1 Networking hardware
 - .2 Wireless hardware
 - .3 Telephone hardware
 - .4 Appropriate licensing for each
- .2 Based on budgetary figures provided to the project by IT Services during the design phase, IT Services will purchase, deploy, and configure all active components that are required for voice and data services.

27 22 00 Data Communications Hardware

- .1 When possible, all servers should be housed in an IT Services data center, unless otherwise approved by IT Services. This will reduce the significant overhead costs associated with small data center construction and operation and reduce the environmental footprint of these systems. Due to the scale and level of support available through IT Services, system reliability is usually higher in this scenario as well. IT Services can provide further information as required.
- .2 Any UofL Facilities Department device (HVAC, Electrical, CCTV, etc.) that is to be connected to the UofL network will require a logical IP assigned to it that will be location dependent. All requests for network connectivity are to be submitted to the Project Manager, who will in turn request this from the Facilities Technology Coordinator.

The following information is required in this request:

- 1. Device Information
 - a. Make
 - b. Model
 - c. MAC Address
 - d. Purpose
- 2. Room or Location Information
 - a. Room number where the device is located
 - b. Room where the network wiring is terminated (wiring closet)
 - c. Port label information
 - d. Network cable test result, if applicable for a new data run

- .3 Any non-Facilities Department device that is to be connected to the UofL network will require a logical IP assigned to it that will be location dependent. All requests for network connectivity are to be submitted to the IT Services Help Desk.

The following information is required in this request:

1. Device Information
 - a. Make
 - b. Model
 - c. MAC Address
 - d. Purpose
2. Room or Location Information
 - a. Room number where the device is located
 - b. Room where the network wiring is terminated (wiring closet)
 - c. Port label information
 - d. Network cable test result, if applicable for a new data run.

27 31 00 Voice Communications Switching and Routing Equipment

27 31 23 Internet Protocol Voice Switches

- .1 The University of Lethbridge has standardized on a Cisco IP Telephony phone system. All projects are required to adhere to this standard and all nonstandard telephony components must be interoperable with our centralized telephony infrastructure.

27 32 00 Voice Communications Terminal Equipment

27 32 13 Telephone Sets

- .1 The IP telephony infrastructure at the UofL is an ethernet based system and as such requires network connections for each telephone set.
- .2 IP Telephony phones and all supporting network infrastructure will be required for all major renovations and new projects.
- .3 Wall phones
 - .1 The Standard mounting height for Wall phones shall be +1400mm (55") AFF to center of box (single gang plaster ring), with a minimum of 350 mm (14") radius of clear wall space.
 - .2 Install a single CAT6A cable, terminated in the communications closet on the NORDX/CDT terminal block and RJ45 (white SL) jack on the terminal end.
 - .3 Label each end as the next jack in the room-labeling scheme.
 - .4 Install a single gang wall jack with protruding wall-mounting studs.

- .4 Classroom phones
 - .1 Classroom phones are to be mounted in locations approved by IT Services.
- .5 Help phones – inside locations
 - .1 To ensure compatibility with the University telephone systems, all help phones must be tested and approved by IT Services. It is highly recommended that a single vendor be chosen across the University campus.
 - .2 Install a single Cat 5e (or CAT6A) cable, terminated in the communications closet on the NORDX/CDT terminal block and RJ45 (white SL) jack on the terminal end.
 - .3 For distances exceeding 100m from the communications closet, analog sets will be required. For distances under 100m from the communications closet, IP sets may be used after consultation with IT Services.
- .6 Help Phones – outdoor locations
 - .1 To ensure compatibility with the University telephone systems, all help phones must be tested and approved by IT Services. For specific devices refer to 28 05 31.
 - .2 Install a single, direct bury, armored, shielded, Cat 5e (or CAT6A) cable, terminated in the communications closet on the NORDX/CDT terminal block and RJ45 (white SL) jack on the terminal end. Cable is to be installed in PVC conduit to allow for simple replacement of the cable.
 - .3 For distances exceeding 100m from the communications closet, analog sets will be required. For distances under 100m from the communications closet, IP sets may be used after consultation with IT Services.
- .8 Elevator telephones
 - .1 Provide two (2) CAT6A lines from the nearest communications room to the main elevator room, terminated in the communications closet on the NORDX/CDT terminal block and RJ45 (white SL) jack on the terminal end.

28 00 00 ELECTRONIC SAFETY AND SECURITY

28 05 31 Communication Equipment for Electronic Safety and Security

- .1 For pole: ETP-MT/R – Radius Tower mount with blue light/strobe (10"x12"x9.5")
- .2 For Phone: ETP-500E – ETP-500 Series analog call station. Indoor/outdoor and emergency button/signage.

28 10 00 Electronic Access Control

28 10 01 Description of Work

- .1 Contractor shall provide a complete rough-in for a card access system as indicated on the drawings and specifications. Complete rough-in to include conduit, back boxes, junction boxes, wiring (cabling to end devices) and 120V hookups.
- .2 Access control system components, including end devices and control components, will be supplied and installed by Honeywell.
- .3 Coordinate installation of card access system rough-in with all sub-trades affected by the work.

28 10 05 Products

- .1 Back boxes:
 - .1 Unless otherwise noted, provide single gang electrical boxes in locations as shown on drawings.
 - .2 Supply blank cover plates where back box is for rough-in for “future” device only.
 - .3 Exterior blank cover plates to be c/w weather resistant gasket.
- .2 Conduit:
 - .1 All “home run” conduit to be minimum of 19mm (unless otherwise specified on drawings or feeding multiple doors).
 - .2 End devices may be fed with 13mm conduit.
 - .3 End devices may be fed with flexible conduit if installing into existing walls
- .3 Devices—the following devices that are typically provided by the Honeywell: unless otherwise specified:
 - .1 Door position magnetic switch (circular recessed type).
 - .2 Magnetic lock.
 - .3 Request to exit (REX) motion sensor.
 - .4 Card reader.
 - .5 Audible alarm or horn.
 - .6 Emergency blue pull station.

28 10 10 Execution

- .1 Install conduit, back boxes and cover plates (as indicated on drawings) for all card access system components as shown on drawings.

- .2 All spare conduit to be complete with pull-string.
- .3 Clearly mark each end of conduit with unique identifying tag indicating what back box or junction box it is running from and that it is reserved for security system.
- .4 All conduit runs must be installed on secure side of door where possible.
- .5 All conduit to be EMT, except where indicated on drawings. Flex is only allowed for end device locations such as from ceiling junction box to end device location only.
- .6 Junction boxes are NOT permitted in unsecured areas.

28 10 15 Cabinets

- .1 Install all security cabinets (as supplied by Honeywell) on plywood backing in security/data rooms and terminate conduit runs into the cabinets.
- .2 Run all cabling from security end devices to control cabinets without splices.
- .3 Provide 120-volt, 15 amp dedicated circuit at security backboard locations for all power supplies and security hardware. Circuits to be terminated in cabinet.
- .4 Identify 120VAC circuit numbers inside each cabinet.

28 10 20 Cable and Cable Tagging

- .1 Supply and install all cables as per plans, schedules and manufacturer's minimum specifications.
- .2 All cables are to be tagged on both ends as per plans and schedules, indicating device type and location. Tags are to be mechanically printed or handwritten. Writing on the cable jacket is not acceptable.
- .3 Leave at least two (2) meters of spare cable at each field device location.
- .4 In each cabinet, leave twice the diagonal width of the cabinet as spare cable length.

28 10 25 Cables

- .1 All cabling for the Access Control System must be installed in conduit from the end device to the control panel. At no time shall the cable tray network be used for the Access Control cable unless approved by U of L.
- .2 The following is a sample list of standard Belden Cable numbers and their description. All wiring references are based on Belden numbers and color codes. Alternate cable types are acceptable if they meet or exceed the minimum specifications of the following Belden cables.

Card Access System Cabling to End Device Requirements			
<u>Device</u>	<u>Min # of wires req'd per device</u>	<u>Wire size (AWG)</u>	<u>Standard Belden Cable #</u>
Card Reader or Prox	3 pr stranded, shielded	22	9513
Door Status Switch	2 pr stranded, shielded	22	8723
Motion Sensor Request to Exit (REX)	2 pr stranded, shielded	22	8723
Panic Bar Microswitch REX	1 pr stranded, shielded	22	8451
Pushbutton REX	1 pr stranded, shielded	22	8451
Keyed Switch REX	1 pr stranded, shielded	22	8451
Emergency Pull station Release and REX	2 pr stranded, shielded	22	8723
Audible Door Alarm Horn or Siren	1 pr stranded, shielded	18	9318
Magnetic Lock	1 pr stranded, shielded	18	9318
Electric Door Strike	1 pr stranded, shielded	18	9318
Panic Hardware Electric Latch Retraction	1 pr stranded, shielded	18	9318
Automatic Door Opener interlock	2 pr stranded, shielded	22	8723

28 13 00 Access Control

28 13 19 Access Control Systems Infrastructure

Refer to Typical Access Control Door – A, B, C, D, and E for card access system installations.

Diagram 28 13 19-1 Typical Access Control Door A

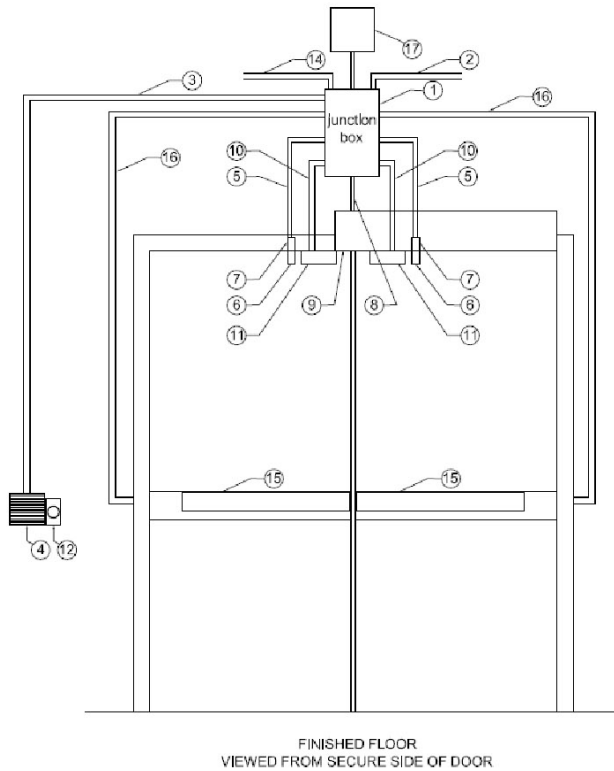

NOTES:

- 1 JUNCTION BOX (10" X 10" min.) MOUNTED ABOVE DOOR IN VOID ABOVE FINISHED CEILING ON SECURE SIDE OF DOOR.
- 2 25mm. CONDUIT RUN FROM FIRST DOOR TO SECOND DOOR (IF NEEDED). RUN ALL WIRING FOR ALL DEVICES BACK TO DOOR CONTROLLER AS NEEDED.
- 3 13mm. CONDUIT FROM JUNCTION BOX TO CARD READER.
- 4 CARD READER MOUNTED ON NON SECURE SIDE OF DOOR.
- 5 13mm. CONDUIT FROM JUNCTION BOX TO DOOR CONTACT IN DOOR FRAME. DOOR CLOSURE HARDWARE MUST NOT INTERFERE WITH THE INSTALLATION OF THE DOOR MAGNETIC IN THE TOP OF THE DOOR.
- 6 DOOR POSITION MAGNET
- 7 RECESSED CIRCULAR DOOR CONTACT.
- 8 19mm. CONDUIT FROM JUNCTION BOX TO AUTODOOR OPERATOR.
- 9 AUTODOOR OPERATOR (BY OTHERS)
- 10 13mm. CONDUIT FROM JUNCTION BOX TO MAGNETIC LOCK.
- 11 MAGNETIC LOCK (BY DOOR HARDWARE CONTRACTOR). OR SEE NOTE 17.
- 12 HANDICAPPED REQUEST TO ENTER BUTTON (BY OTHERS) MOUNTED ON NON SECURE SIDE OF DOOR.
- 13 HANDICAPPED REQUEST TO EXIT BUTTON (BY OTHERS).
- 14 37mm. CONDUIT RUN FROM CONTROL PANEL OR 25mm. FROM FIRST DOOR. RUN ALL WIRING FOR ALL DEVICES BACK TO DOOR CONTROLLER AS NEEDED.
- 15 PANIC BAR RELEASE DEVICE C/W REQUEST TO EXIT SWITCH AND EMERGENCY MAGLOCK RELEASE SWITCH (BY OTHERS).
- 16 13mm. CONDUIT RUN FROM JUNCTION BOX TO TRANSFER HINGE OF PANIC BAR RELEASE DEVICE.
- 17 SEPERATE 24VAC POWER SUPPLY REQUIRED IF DOOR USES ELECTRIC LATCH RELEASE. LOCATED NEAR DOOR. (BY DOOR HARDWARE CONTRACTOR).
- 18 MOTION REQUEST TO EXIT SENSOR.

1 **TYPICAL ACCESS CONTROL DOOR - A**
CARD ACCESS - DOUBLE DOOR - MAGNETIC LOCK - AUTODOOR OPERATOR
SCALE NTS

Diagram 28 13 19-2 Typical Access Control Door B

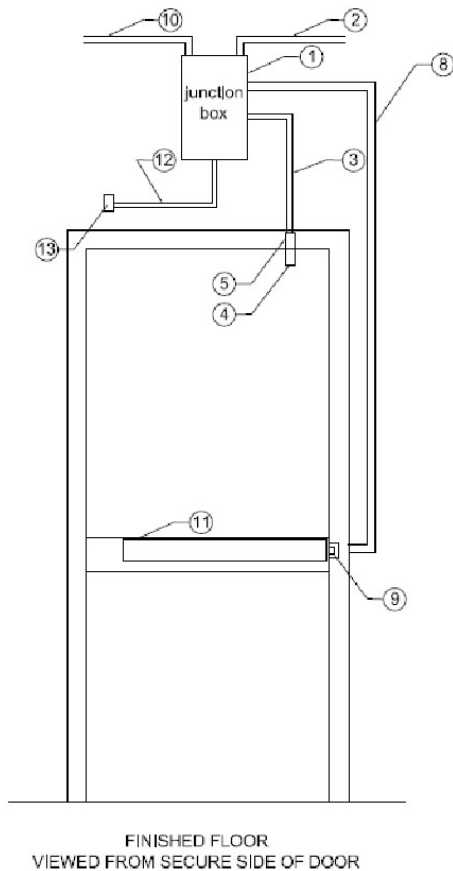

NOTES:

- 1 JUNCTION BOX (6" X 6" min.) MOUNTED ABOVE DOOR IN VOID ABOVE FINISHED CEILING ON SECURE SIDE OF DOOR.
- 2 25mm. CONDUIT RUN FROM FIRST DOOR TO SECOND DOOR (AS NEEDED). RUN WIRING FROM DOOR DEVICES TO CONTROLLER AS NEEDED.
- 3 13mm. CONDUIT FROM JUNCTION BOX TO DOOR CONTACT IN DOOR FRAME. OBSERVING DOOR CLOSURE HARDWARE SO THAT IT DOES NOT INTERFERE WITH THE INSTALLATION OF THE DOOR MAGNETIC IN THE TOP OF THE DOOR.
- 4 DOOR POSITION MAGNET.
- 5 RECESSED CIRCULAR DOOR CONTACT.
- 6 13mm. CONDUIT FROM JUNCTION BOX TO SIREN 4 IN. SQ JUNCTION BOX
- 7 MULTI-TONE ADJUSTABLE VOLUME SIREN.
- 8 13mm. CONDUIT FROM JUNCTION BOX TO DOOR STRIKE.
- 9 ELECTRIC STRIKE (BY DOOR HARDWARE CONTRACTOR).
- 10 37mm. CONDUIT RUN FROM CONTROL PANEL OR 25mm. FROM FIRST DOOR. RUN WIRING CONTINUOUSLY FROM DEVICES TO CONTROL PANEL AS NEEDED.
- 11 PANIC BAR (BY DOOR HARDWARE CONTRACTOR).
- 12 13mm. CONDUIT FROM JUNCTION BOX TO MOTION REX.
- 13 MOTION REQUEST OT EXIT SENSOR.

2 **TYPICAL ACCESS CONTROL DOOR - B**
CARD ACCESS - SINGLE - ELECTRIC STRIKE - PANIC - SIREN
SCALE NTS

Diagram 28 13 19-3 Typical Access Control Door C

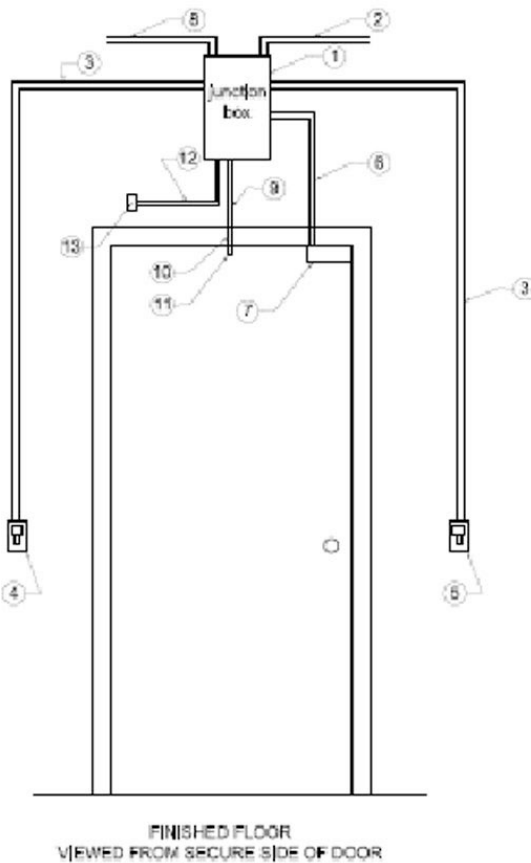

NOTES:

- 1 JUNCTION BOX (8" X 6" min.) MOUNTED ABOVE DOOR IN VOID ABOVE FINISHED CEILING ON SECURE SIDE OF DOOR.
- 2 25mm, CONDUIT RUN FROM FIRST DOOR TO SECOND DOOR (AS NEEDED), RUN ALL WIRING CONTINUOUSLY FROM DEVICES BACK TO DOOR CONTROLLER.
- 3 13mm, CONDUIT FROM JUNCTION BOX TO BLUE PULL STATION.
- 4 EMERGENCY BLUE PULL STATION MOUNTED ON INCH - SECURE SIDE OF DOOR
- 5 EMERGENCY BLUE PULL STATION MOUNTED ON SECURE SIDE OF DOOR
- 6 13mm, CONDUIT FROM JUNCTION BOX TO MAGNETIC LOCK.
- 7 MAGNETIC LOCK
- 8 37mm, CONDUIT RUN FROM CONTROL PANEL OR 25mm, FROM FIRST DOOR, RUN WIRING CONTINUOUSLY FROM DEVICES TO CONTROL PANEL AS NEEDED.
- 9 13mm, CONDUIT FROM JUNCTION BOX TO DOOR CONTACT IN DOOR FRAME, DOOR CLOSURE HARDWARE MUST NOT INTERFERE WITH THE INSTALLATION OF THE DOOR MAGNETIC IN THE TOP OF THE DOOR.
- 10 DOOR POSITION MAGNET
- 11 RECESSED CIRCULAR DOOR CONTACT
- 12 13mm, CONDUIT FROM JUNCTION BOX TO MOTION REQ.
- 13 MOTION REQUEST OR EXIT SENSOR.



TYPICAL ACCESS CONTROL DOOR - C

ACCESS CONTROL - SINGLE DOOR - MAGNETIC LOCK

SCALE: NTS

Diagram 28 13 19-4 Typical Access Control Door D

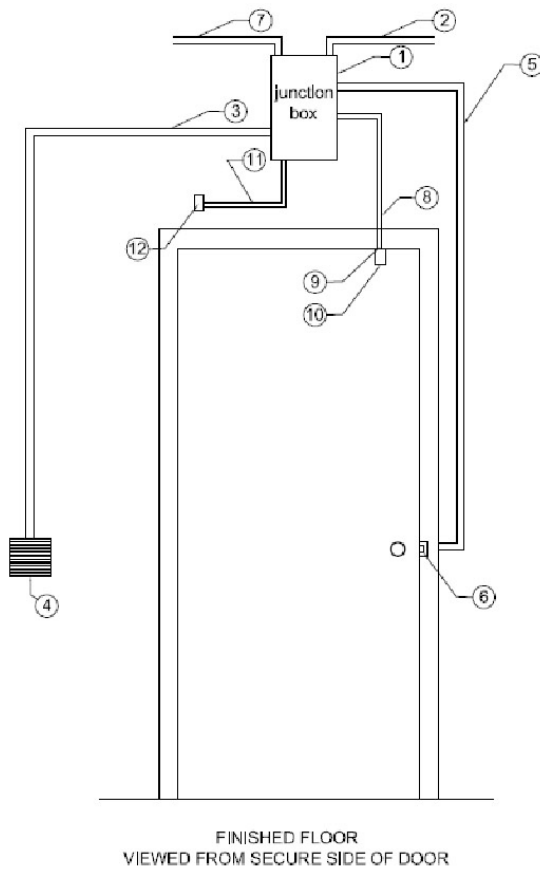

NOTES:

- 1 JUNCTION BOX (6" X 6" min.) MOUNTED ABOVE DOOR IN VOID ABOVE FINISHED CEILING ON SECURE SIDE OF DOOR.
- 2 25mm. CONDUIT RUN FROM FIRST DOOR TO SECOND DOOR (AS NEEDED), RUN WIRING FROM DOOR DEVICES TO CONTROLLER AS NEEDED.
- 3 13mm. CONDUIT FROM JUNCTION BOX PROXIMITY READER.
- 4 CARD READER MOUNTED ON NON-SECURE SIDE OF DOOR.
- 5 13mm. CONDUIT FROM JUNCTION BOX TO DOOR STRIKE.
- 6 ELECTRIC STRIKE.
- 7 37mm. CONDUIT RUN FROM CONTROL PANEL OR 19mm. FROM FIRST DOOR, RUN WIRING FROM DEVICES TO CONTROL PANEL AS NEEDED.
- 8 13mm. CONDUIT FROM JUNCTION BOX TO DOOR CONTACT IN DOOR FRAME, DOOR CLOSURE HARDWARE MUST NOT INTERFERE WITH THE INSTALLATION OF THE DOOR MAGNETIC IN THE TOP OF THE DOOR.
- 9 DOOR POSITION MAGNET
- 10 RECESSED CIRCULAR DOOR CONTACT
- 11 13mm. CONDUIT FROM JUNCTION BOX TO MOTION REQ.
- 12 MOTION REQUEST OR EXIT SENSOR.

4
TYPICAL ACCESS CONTROL DOOR - D
CARD ACCESS - SINGLE DOOR - ELECTRIC STRIKE
SCALE: NTS

Diagram 28 13 19-5 Typical Access Control Door E

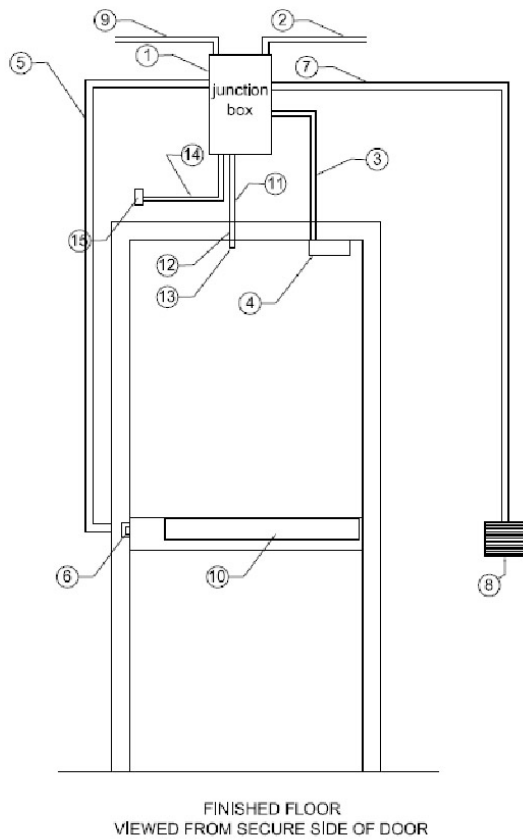

NOTES:

- 1 JUNCTION BOX (6" X 6" min.) MOUNTED ABOVE DOOR IN VOID ABOVE FINISHED CEILING ON SECURE SIDE OF DOOR.
- 2 25mm. CONDUIT RUN FROM DOOR TO SECOND LOCATION (AS NEEDED), RUN WIRING CONTINUOUS FROM DOOR DEVICES TO CONTROLLER AS NEEDED.
- 3 13mm. CONDUIT FROM JUNCTION BOX TO MAGLOCK.
- 4 MAGLOCK (BY DOOR HARDWARE CONTRACTOR).
- 5 13mm. CONDUIT FROM JUNCTION BOX TO TRANSFER HINGE.
- 6 TRANSFER HINGE (BY DOOR HARDWARE CONTRACTOR).
- 7 13mm. CONDUIT FROM JUNCTION BOX TO CARDREADER.
- 8 CARDREADER
- 9 37mm. CONDUIT RUN FROM CONTROL PANEL OR 25mm. FROM FIRST DOOR. RUN WIRING CONTINUOUSLY FROM DEVICES TO CONTROL PANEL AS NEEDED.
- 10 PANIC BAR EQUIPPED WITH ULC MAGLOCK RELEASE DPDT RELAY (BY DOOR HARDWARE CONTRACTOR).
- 11 13mm. CONDUIT FROM JUNCTION BOX TO DOOR CONTACT IN DOOR FRAME. OBSERVING DOOR CLOSURE HARDWARE SO THAT IT DOES NOT INTERFERE WITH THE INSTALLATION OF THE DOOR MAGNETIC IN THE TOP OF THE DOOR..
- 12 DOOR POSITION MAGNET
- 13 RECESSED CIRCULAR DOOR CONTACT
- 14 13mm. CONDUIT FROM JUNCTION BOX TO MOTION REX.
- 15 MOTION REQUEST OR EXIT SENSOR.

10 **TYPICAL ACCESS CONTROL DOOR - E**
ACCESS CONTROL - SINGLE DOOR - MAGLOCK - PANIC
 SCALE: NTS

28 15 00 **Intrusion Detection**

28 30 00 **Fire Detection and Alarm**

- .1 Fire alarm systems shall be connected to normal and emergency power. Battery backup power shall be provided in the fire alarm control panel in accordance with NFPA requirements.
- .2 Control panels shall be of modular design for ease of system expansion and shall be protected with adequate built in surge suppression.
- .3 Additional devices may be requested by the University of Lethbridge.
- .4 The University Electrical Department requires a MINIMUM of 24 hours' notice prior to any fire alarm system shutdowns or work.
- .5 Fire alarm system shall be maintained throughout the duration of a project. If system is not functioning or cannot function, a fire watch shall be maintained.
- .6 Fire watch becomes the responsibility of the contractor to provide such.

28 30 05 *Fire Detection System*

- .1 Fully addressable and communicate with the existing system (All equipment and components shall be the manufacturer's current model) Suggested Manufacturer: Chubb Edwards.
- .2 New equipment only.
- .3 New system to be 100% compatible with the existing University of Lethbridge campus fire alarm system.

28 30 10 *Installation*

- .1 The equipment and installation shall comply with the current provisions of the ULC codes and standards.
- .2 Comply with National, Provincial and Local Building Codes.
- .3 Comply with Canadian Electrical Code.
- .4 Comply with International Standards Organization.
- .5 Comply with Local Authority having jurisdiction.
- .6 Co-ordinate and schedule verification.
- .7 Remove and reinstall devices.

- .8 Contractor shall verify in writing that he is authorized and approved by the manufacturer of the equipment to make the installation.
- .9 Co-ordinate and schedule work around classes and other events.
- .10 Smoke and Duct detectors: maximum level of 5% "dirtiness" at time of turnover to U of L.
- .11 Provide 10% spare smoke detectors to University at turnover.

28 30 15 Manufacturer

- .1 Provide all programming and programming changes as required.
- .2 Insure correct operation of all system alarms, trouble and auxiliary functions.
- .3 Record all data and issue report and certificate of verification.

28 30 2 0 Engineering

- .1 Direct and supervise verification.
- .2 Ensure that system is applied and installed to all applicable Codes.
- .3 Record verification information to be included in final report.

28 30 25 Wiring

- .1 Paint all new and existing junction boxes (exposed or in ceiling spaces) red.
- .2 All wiring shall be installed in conduits. Conduit to be banded with red tape every 1.5 m (5 feet).
- .3 Wiring for fire detection/alarm systems shall be of the type and size as recommended by the fire alarm system manufacturer.
- .4 Wiring shall be of multi conductor cable type listed and approved for use as fire alarm system wiring.
- .5 All addressable devices shall be tagged to indicate device address; panel, loop ID and device number (i.e.: 01 01 0001). Affix label to detector base, not detector itself.
- .6 Confirm label location and specific labeling sequence/protocol with the Owner.
- .7 All wiring to be Class A for the network, loop controllers and devices.
- .8 "T" taps are not permitted.

28 30 28 Fibre Optic Cable

- .1 Single mode.

28 30 30 Completion

- .1 Provide sequence of operation of audible devices when in multi-zone areas or adjoining buildings.
- .2 Provide sequence of operation for any systems interconnected to the fire alarm system (i.e. air handling unit shutdown, fire suppression systems, door holds/locks, elevators).
- .3 As-built wiring drawings.
- .4 VI reports from Engineering firm, manufacturer, and local authority having jurisdiction.

28 30 35 Warranty

- .1 Contractor and Fire Alarm / Life Safety System manufacturer shall warrant the installed system for a period of one (1) year.

28 30 40 FireWorks

- .1 Contractor is responsible for updating the FireWorks® monitoring system, unless otherwise directed by University Project Manager.
- .2 Contractor to confirm with University Electrical Dept. if additional costs will be associated with FireWorks® updates.

28. Commissioning TO BE MOVED

- .1 All construction work will be commissioned by a U of L representative (commissioning agent).**
- .2 Commissioning agent will be granted access to project site.**

2x xx 05 As-built drawings

- .1 All electrical work requires as-built drawings.**

2x xx 10 Operation and Maintenance Manuals

- .1 Manuals to be hard cover, post style expandable binders.**
- .2 All sections to be clearly identified and separated.**
- .3 Binders to be identified using permanent embossed lettering on the front and the spine.**
- .4 Binder to have spare space for 25% growth.**

28 40 00 **Life Safety**

28 45 00 **Water Detection and Alarm**

28 45 13 *Water Detection Sensors*

- .1 Devise architectural façade concepts that are technically feasible and integrated with principles of environmental design including appropriate responses to building and solar orientation, high window performance, continuous air and liquid moisture and vapour barrier systems, pressure equalized rain screen design, passive solar, hybrid and active systems.
- .2 The architect, in coordination with a building envelope specialist and mechanical engineer, must be involved in the design of the building envelope and related mechanical systems. Where possible, buildings should first be designed with only the necessary dependence on active mechanical systems for the specific building design.

28 45 15 *Building Envelope Water Detection and Alarm*

- .1 Provide complete building envelope systems that address the life cycle, durability, maintenance and overall thermal, air tightness and moisture management performance of wall, roof and slab systems which provide continuity of assemblies and reduce long term operating costs.

28 46 00 **Water Detection and Alarm**

- .1 To be determined in a subsequent Standards revision. See related sections.

31 00 00 **EARTHWORK**

31 09 00 **Geotechnical Instrumentation and Monitoring of Earthwork**

31 10 00 **Site Clearing**

- .1 An excavation permit must be obtained from the authority having jurisdiction prior to any ground breaking operation. U of L to assist utility to locate.
- .2 Contractor must remove from the site all excess materials produced as a result of site preparations and excavations.
- .3 Contractor is to ensure that access and haul roads are free of mud, dirt and debris caused by site preparations and excavations.
- .4 Excavated topsoil and subsoil may be stockpiled on site if space allows in compliance with existing cut and fill plan.
- .5 Spoil removal sites must be coordinated with the existing cut and fill plan.

- .6 All hydro-vac trucks coming onto campus must have clean tanks containing no hazardous materials from previous use. This cleanliness will likely require all trucks to have a fully opening rear door for proper cleanout.
- .7 All hydro dig spoils must be disposed of or processed in a manner that is approved by the U of L. All spoil containing Hazardous Waste must be transported off campus and legally disposed of at an approved Waste management facility. We will only consider allowing on-campus dumping of spoils that are not hazardous. The U of L may allow dumping of some “waste” materials on campus if they are deemed to be of no detrimental effect in the present or the future. Approved methods of disposal for spoils without Hazardous Waste will include:
 - .1 Legal transportation off-campus at the contractor’s expense. OR
 - .2 Dumping in a location approved by the Grounds Manager on campus with a plan for containment and rehabilitation of the dumping site. The temporary dumping sites on campus must have provision for containing storm water runoff in the event of precipitation to prevent silt from entering the storm water infrastructure or the river system causing an adverse environmental effect. The containment system must not create a hazardous pit.
 - .3 Rehabilitation will require amendment of the soil with organics approved by the U of L to provide soil structure and nutrients to support healthy plant life and installing approved plant materials to restore the area.

31 20 00 Earth Moving

31 30 00 Earthwork Methods

- .1 When soil is compacted in winter it tends to slump away from sidewalks and curbs as the ground thaws in the spring. This is an undesirable outcome. A soil compaction of 95-97% is required.

31 40 00 Shoring and Underpinning

- .1 Contractor is to provide own shoring.

31 50 00 Excavation Support and Protection

- .1 All construction shall employ the services of a Geotechnical Engineer who will perform an analysis of the existing site along with recommendations for possible building foundations.
- .2 The main campus has unique soil conditions and an elevated water table that become issues for both shallow and deeply excavated buildings (such as University Hall, the Centre for Sport and Wellness, and others).

Related Documents

University of Lethbridge Slope Stability Review - University Hall (2013), AMEC

32 00 00 **EXTERIOR IMPROVEMENTS**

32 01 80 *Operation and Maintenance of Irrigation*

- .1 Buried irrigation lines are to have tracer wires installed.

32 05 00 **Common Work Results for Exterior Improvements**

- .1 Where applicable, exterior handrails are to be placed at the sides of concrete walls, not on top of the walls. This placement reduces the degradation of the materials.
- .2 Provide unobstructed firefighting access to all buildings and public campus areas to ensure life safety of occupants and the adequate access and protection of campus assets.
- .3 Due to the nature of the coulee setting, some building sites are not easily accessible from all sides or elevations. To the maximum practical extent, practices to be considered include consideration for various types of requirements for firefighting access as a result of fire situations within or around buildings (including potential prairie fires originating elsewhere).
- .4 Where applicable, exterior handrails are to be located to assist pedestrians, preferably mounted at the sides of concrete steps and walks, rather than embedded in the top of walking surfaces which create durability and maintenance issues

Related Documents

University Hall – Building Code and Life Safety Review (2009), Sereca Fire Consulting Ltd.

32 06 00 **Schedules for Exterior Improvements**

- .1 The recommended envelope design approach for campus buildings is a “pressure equalized rainscreen” and insulated structure technique”. This approach is characterized by the following:
 - Exterior cladding covering an air space, pressure equalized with the exterior environment.
 - An adhered air sealing component to the exterior of structural frame and structural infill. The air sealing component in combination with the underlying structural elements forms the air barrier system.
 - Insulation in direct and firm contact with the air barrier system.
 - Materials used should be suitable for the environmental conditions and should provide a service life consistent with the planned building life. Consider accessibility for purposes of maintenance of the building components.
 - Provide suitable drainage and venting to minimize moisture, drain moisture adequately and quickly dry areas that become moist.
 - Elements that penetrate the building envelope should be avoided. Where they occur, thermal separation and control will be necessary, as will considerations for membrane and air barrier integrity.
 - Where detailing for exterior envelope finishes appear to continue to the interior, an appropriate seal at the breakpoint of transition will be necessary.

32 10 00 Bases, Ballasts, and Paving

- .1 Sidewalks must have as a minimum a 1.5m (5 ft.) clear width. This width is separate from rolled curbs, signposts, or fire hydrants. These intrusions hinder the use of snow clearing equipment and must be kept beyond the 1.5m (5 ft.) allowance. Avoid the use of 90 degree or acute angles unless the corners are rounded off. This will facilitate snow clearing activities and ease of movement for those with mobility issues.
- .2 Due to the extremes of climate found in Lethbridge, it is essential that the steel reinforcement in sidewalks be correctly installed. It must be maintained at 1/3 of the distance measured from the concrete sidewalk base. Rebar pushed to the bottom of the pour will not be accepted.
- .3 A 2.44m (8 ft.) minimum clearance is required above sidewalks to allow for grounds equipment to be used in those locations.
- .4 Sidewalks must have as a minimum a 1.5m (5 ft.) width. This width is separate from rolled curbs, signposts, or fire hydrants. These intrusions hinder the use of snow clearing equipment and pedestrian traffic flow, particularly for the less able. Avoid the use of 90 degree or acute angles. See figure 32 10 00-A below.

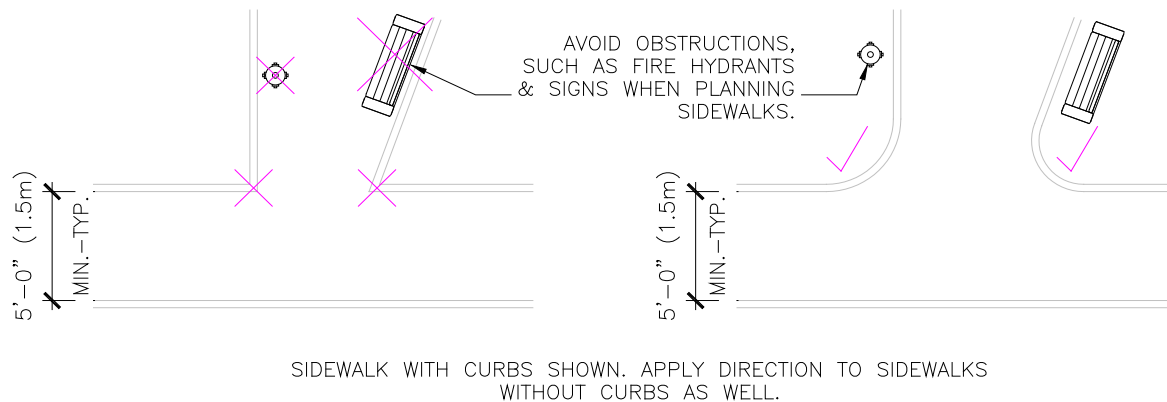

Figure 32 10 00-A

- .5 Due to the extremes of climate found in Lethbridge, it is essential that the steel reinforcement in sidewalks be correctly installed. It must be maintained at 1/3 of the distance measured from the concrete sidewalk base. Rebar pushed to the bottom of the pour will not be acceptable.
- .6 A 2.44m (8 ft.) minimum clearance is required above sidewalks to allow for grounds equipment to be used in those locations.

32 13 00 Rigid Paving

- .1 All concrete surfaces are to integrate expansion and control joints which are to be smoothly tooled and located to effectively manage cracking. An initial broom finish should extend the full width of the surface from edge to edge, preventing a trowelled appearance at joints and, optionally, lightly sandblasted.

32 30 00 **Site Improvements**

32 80 00 **Irrigation**

- .1 If irrigation is provided, the control panels are to be located on the exterior of the building or in the Grounds storage room of the building. All exterior control panels are to have protective housings with a locking mechanism.
- .2 For irrigation installation standards and previously approved manufacturers, please refer to information provided in the appendix.

Related Documents

http://www.canadanursery.com/Storage/47/5649_CSNS_-_8th_Edition_-_web.pdf

32 90 00 **Planting**

- .1 A living list of appropriate plant materials is to be used for landscaping design. See Appendix. Planting and materials schedule to be approved by U of L. Reference: The International Society of Arboriculture (ISA).
- .2 Landscape and building design should be conceived and designed as a single composition. All campus areas will include signature plant species as a means of unifying the campus landscape. Tree planting for all primary and secondary streets must be consistent. Be aware that when the soil is compacted in winter it tends to slump away from sidewalks and curbs as the ground thaws in the spring. Therefore, a soil compaction of 95-97% is required around sidewalks and curbs.
- .3 Bicycle paths, racks and/or storage are to be part of the landscaping design of any new building.
- .4 Non-native plants detract from the natural landscape surrounding. The objective is for all the buildings and the surrounding site to blend in and enhance the natural coulee setting.
- .5 Plant selection should consider the characteristics during the seasons that the academic semester occurs; fall to spring. Elements to consider include fall colour, bark texture and colour, branching pattern, flowering period and colour, coniferous or deciduous and leaf out time in spring.
- .6 A consistent tree planting strategy at the campus gateway along Aperture Drive and alongside significant spines will enhance place making and wayfinding on campus.
- .7 Existing plant material that is within the boundary of construction projects shall be maintained or replanted elsewhere whenever possible. Plant material and trees that may be affected by construction shall be protected and removed before the risk of damage is present.
- .8 Plans for new plant species and existing plants to remain shall be approved by the Grounds Manager and Project Manager and examined at all stages of removal and installation.

- .9 All sites are to be designed for public and personal safety. The use of dense landscape screens, such as tall hedges, solid fences and long fencing lines that could act as entrapment areas and regions of limited visibility are to be avoided in accordance with CPTED guidelines.
- .10 The following should be considered when specifying plant material:
 - Avoid planting trees too close to buildings by providing appropriate space between a building and mature tree spread to accommodate building maintenance equipment such as swing stages or overhead utility lines.
 - Avoid the use of turf on steep slopes where maintenance is difficult and dangerous. Native drought tolerant plants should be placed in sloped areas.
 - Choose appropriate plant material and mulches in areas that are exposed to extreme wind to avoid mulch that will blow away, plants that will desiccate or shrubs and other plants that will collect litter.
 - Plants must suit the intended uses of the area and irrigation regimen planned for that area. Low maintenance regions will require drought tolerant plants while high traffic regions will require more vigorously growing plants and higher irrigation rates.
 - All plants used in this landscape must be proven performers in our soil, our climate and our traffic conditions. Whenever possible, choose plant species found within 100 kilometers of Lethbridge as a method of ensuring that these species will be suitable to our growing conditions.
 - Avoid plants with high maintenance needs such as pruning, fertility, disease, pests, irrigation, drainage, dropping of leaves, needles or fruit, etc.
 - Plantings need to take location into account for issues such as wind, sunlight and shade, drainage, capacity for creating or catching litter, fruit or leaf production, attraction to nuisance insects or animals, sight lines on campus for both pedestrian and vehicular traffic, summer and winter appearance, disease resistance, drought tolerance, flood tolerance, snow drift creation, natural size of plants, maintenance requirements and past performance of species on campus.

33 00 00 UTILITIES

33 01 00 Operation and Maintenance of Utilities

- .1 All surface and underground works, unless otherwise noted herein, should be in accordance with the City of Lethbridge Infrastructure Services Construction Specifications.
- .2 Locates for below grade utilities are to be performed by University Utilities department by work order request.
- .3 The Electrical Design Consultant is required to physically examine the site and verify existing conditions and to review the work area. The Electrical Design Consultant shall meet with the University Utilities Electrical Manager to develop and prepare a program and layout for all new buildings and renovations.
- .4 Domestic potable water is treated and supplied by the City of Lethbridge. The University does not treat or filter water except for a small number of reverse osmosis units or water softener

applications for laboratory spaces. Facilities has experimented with chemical free water applications for cooling towers with inconclusive outcomes versus chemically treated water.

33 14 00 Water Utility Transmission and Distribution

- .1 The consultant in conjunction with the Utilities Department will determine the locations of domestic water service tie-ins. All tie-in methods must be approved by the Utilities Department. Domestic water service is treated and provided by the City of Lethbridge and integrated with campus facilities.

33 50 00 Hydrocarbon Utilities

- .1 Buried natural gas lines are to have tracer wires installed.
- .2 All-natural gas piping to be in conformance with the latest edition of CAN/CSA B149.1.
- .3 To be determined in a subsequent Standards revision. See related Appendix sections.

33 70 00 Electrical Utilities

- .1 Main electrical equipment rooms shall be generally located within the core areas of the facility and shall be stacked vertically. An adequate number of electrical rooms serving no more than 930 m² of floor area shall be provided with minimum clear dimensions of 1800 mm by 3000 mm. If transformers are in the rooms, ventilation must be provided.
- .2 Electrical (and mechanical) rooms require a minimum of one emergency power receptacle identified as such at the receptacle.
- .3 Existing buildings shall only have loads connected to the emergency power system as required by the University and governing codes.
- .4 Equipment in new structures such as fire alarm systems, emergency lighting and security panels shall be provided with emergency backup power. All other equipment will be identified for emergency power on a case-by-case basis and may include fire pumps, telephone switches, mechanical control systems, Building Automation System (BAS), select elevators, sump pumps, smoke control systems, UPS serving technology or server rooms, exhaust fan or air conditioning in UPS supplied server and communication rooms, laboratory fume hoods and supply fans that maintain building pressurization.
- .5 Bus ducts for secondary branch power distribution shall be copper, fully rated, 3-phase/4 wire with 100% neutral and an integral ground bus sized at 50% of the phase bus. Calculations are to be provided supporting the specified short circuit rating.
- .6 Distribution conductors shall be RW90, XLPE and minimum #12 AWG for all branch circuits. The base specification shall require copper be utilized throughout including motor and transformer windings, switchgear bussing, switchboard and panel board bussing, bus duct, primary and secondary feeders, branch feeders and branch circuits. Aluminum is not permitted.

- .7 Group Motor Control Centres shall be used where eight (8) or more starters are required in an equipment room. MCC construction shall be NEMA Class I, Type B, copper, with magnetic (or solid state, if appropriate) starters and molded case circuit breakers. Minimum starter size in MCC shall be size 1 and control circuit voltage shall be 120V connected ahead of each starter via a fused control transformer. Control transformer shall be located inside motor starter cubicle. Reduced voltage starters may be used for larger motors to reduce starting kVA.
- .8 All equipment and systems that draw off building power must be in conformance with CAN/CSA C22.2 Product General Requirements, issued under the Canadian Electrical Code, Part II.

33 71 00 Electrical Utility Transmission and Distribution

- .1 A Utility Coordination Study is required if/when new switches or buildings are added to the University's 15kv distribution and emergency power. All switches are to be "dead front" type. Locations of vaults, transformers, meters and other utility items must be coordinated with the architectural design to avoid conflicts with critical architectural features (for example, at main entrances) and must consider both equipment ventilation and removal.
- .2 To ensure maximum flexibility for future systems changes, the electrical system must be sized for the demand load with additional spare capacity as follows:
 - Panel boards for branch circuits: 50% spare ampacity as well as 25% spare circuit capacity.
 - Panel boards serving lighting only: 25% spare ampacity as well as 25% spare circuit capacity.
 - Switchboards and distribution panels: 35% spare ampacity as well as 25% spare circuit capacity.
 - Main Switchgear: 25% spare ampacity as well as 25% spare circuit capacity.
- .3 Prior to adding the spare equipment ampacity to account for future load growth, it is important that the load study reflect actual demand loads rather than connected loads. The designer shall apply realistic demand factors by considering various energy conserving devices such as variable frequency drives applied to brake horsepower, energy efficient motors, occupancy sensors, and so forth. The designer shall also avoid adding the load of stand-by motors and shall be careful to distinguish between summer and winter loads by identifying such 'non-coincidental' loads. Once the estimate 'peak demand' load is established, the factor for load growth should be added.
- .4 A method (or system) to drain the manhole is to also be provided.
- .5 Concrete encased duct banks shall be provided with proper cover of at least 1000 mm with an excavation warning ribbon installed 300 mm above duct bank and shall slope toward manholes. Changes in direction shall be at a radius of 7.5 m or greater. Stub-ups from the bank into electrical equipment shall be installed with manufactured elbows and terminate 100mm above the finish elevation of housekeeping pads. Electrical and communication banks shall be kept clear of all other underground utilities, especially high temperature water or steam. Duct line routes will avoid other underground structures in their coordination and planning. When necessary to run communication cables parallel to power cables, two separate systems must be provided with separate access. The same is true for normal and emergency power distribution banks. Duct banks shall be spaced a minimum of 500 mm apart and be sized for the number

and sizes of cables. Minimum duct sizes for medium voltage services (13.2kV) shall be 155 mm with a minimum of two (2) spare ducts provided for future expansion. Inner ducts must be provided inside communication ducts when fibre optic lines are used.

33 71 19.13 *Electrical Manholes and Handholes*

- .1 Manholes shall be spaced no farther than 150 m apart for straight runs. The distance between the service entrance and the first manhole shall not exceed 30 m. Double manholes shall be used where electric power and communication lines follow the same route. Manholes shall have clear interior dimensions of no less than 1800 mm in depth, length and width with an access opening at the top not less than 570 mm in diameter. Manholes must have a minimum wall space of 1800 mm available on all sides where splices are to be racked and shall be provided with pulling eyes, sumps and grounding provisions, as necessary.

33 74 00 **Extra High Voltage (EHV) Switchgear and protection devices**

- .1 The main switchgear room is to be securely located in a vault or internal to the building along a perimeter wall at an elevation that minimizes the transformer secondary feeder length. Switchgear room door width and height shall accommodate the removal and replacement of the largest piece of equipment and be equipped with panic hardware.

34 00 00 **TRANSPORTATION**

34 05 00 **Common Work Results for Transportation**

- .1 Due to an increase in automobile commuters, transit users, pedestrian and cyclists, and an increase in on-campus residents, vehicular access will be restricted from areas of the core academic campus.
- .2 Larger parking lots are located at the campus periphery. Smaller parking lots are strategically scattered throughout campus for short-term parking needs providing convenient accessible parking adjacent to main access points.
- .3 Although vehicular traffic is restricted from the campus core, service and emergency vehicles have full access to all campus facilities. Access would be along specially widened pedestrian walkways also designed to accommodate service and emergency vehicles.
4. Barrier free access to sidewalks at road crossings should be located at corner and mid-points of dedicated walking surfaces when long sidewalks present additional barriers to less able-bodied persons. Bicycle paths, racks and/or storage to be integrated as part of the landscaping and architectural design of any new building.
5. The design of all pedestrian surfaces and areas are to be fully integrated with adjacent buildings and overall site development on campus in order to provide a consistent material vocabulary and pedestrian-friendly campus.

- .6 Paved surfaces on site should be accessible by all users and be designed in accordance with the Alberta Building Code and Alberta Barrier Free Guide. Paving shall be designed with the flow of traffic in mind, with consideration for 'shortcutting' and damage to landscaping.
- .7 Paving material to be selected should consider drainage and be easy to plough. Acceptable pedestrian paving materials include:
 - Primary pathway surfaces:
 - Concrete with light sandblast finish pattern
 - Coloured concrete
 - Unit pavers with concrete edger
 - Appropriate stone or precast concrete elements
 - Secondary pathway surfaces:
 - Concrete with broom finish pattern
 - Asphalt with concrete edges
 - Durable wood surfaces (limited use)
 - Tertiary pathway surfaces (trails, etc.)
 - Asphalt
 - Crushed local rock material
 - Prohibited pathway materials:
 - Ceramic or glazed tile (including within building entrances).
 - Rubber or plastic (PVC) pavers.
 - Excessive painting as the primary visual cue.
 - Woodchip or bark paths.
- .8 When installing new pathway systems or improving existing pathways, way-finding signage, seating elements, lighting and weather protection should be thoughtfully considered.
- .9 Where pedestrian pathways meet roadways, passable barriers (e.g., of sufficient width or by telescopic bollards) shall be installed in key locations around the pedestrian core to provide access for emergency, security and authorized vehicles while limiting access by other vehicles. Discretion should be used to prioritize pedestrian movement with grounds maintenance. Snow removal equipment typically requires 1.85m clearance, where warranted.
- .10 Incorporate curb cuts and wheelchair ramps in paved areas to accomplish the goal of providing a barrier-free campus accessible by all people. To accommodate for changes in grade, ramps shall be used instead of steps whenever possible. Visual indication of excessive changes in grade should be made evident in accordance with universal design standards by using contrasting materials or trowelled demarcation lines.
- .11 Bollards shall be placed to minimize obstruction to pedestrian flow while defining boundaries for controlled automobile traffic. The minimum clearance between bollards shall be 1200mm with a minimum height shall be 450mm and contrast in colour from the surrounding paving to be more visible. Chains, cables or ropes are discouraged as permanent or temporary barriers unless they are easily visible. They must be placed at a height that can be detected by the visually impaired.

- .12 Trash containers should visually integrate with their environments and be located adjacent to, but not obstruct, walkways. Trash container designs shall include ease of use and exclusion of rain and snow within bins. They shall be operable with one hand and be of accessible height for disabled persons. Ideally, opening flaps help to mitigate wasp nests and scavenging birds which others can create safety concerns and additional grounds maintenance.
- .13 Paving and walkways should be wide enough to permit ease of snow removal equipment and limit hand shoveling. A clear, unobstructed distance of 1.5 m from obstacles to the outside edge of sidewalk is ideal. Where possible, site elements such as signage and fire hydrants are not to intrude on dedicated pedestrian surfaces.

Related Documents

Barrier-free design guide. Fifth edition - Open Government (alberta.ca)

40 00 00 PROCESS INTERCONNECTIONS

40 01 00 Operation and Maintenance of Process Interconnections

40 01 10 Operation and Maintenance of Gas and Vapor Process Piping

40 01 20 Operation and Maintenance of Liquids Process Piping

40 01 30 Operation and Maintenance of Solid and Mixed Materials Piping and Chutes

40 01 40 Operation and Maintenance of Process Piping and Equipment Protection

40 01 60 Operation and Maintenance of Process Control and Process Facility

40 01 70 Operation and Maintenance of Instrumentation for Process Systems

40 01 90 Operation and Maintenance of Primary Control Devices

40 05 00 Common Work Results for Process Interconnections

40 05 81.13 Fire Hydrants

- .1 Fire hydrants are to be McAvity M67 only.
- .2 The exterior of the hydrant shall be coated, painted red.
- .3 Hydrants are required to have drains plugged.
- .4 Hydrant shall be placed on concrete pads.
- .5 The end of the ditch at the rear of the hydrant shall be filled with concrete to the level of the top of the pipe and clear of the hydrant drain hole to anchor the hydrant. A pit for drainage 750mm wide 1000mm long and 60mm deep shall be dug at the foot of the hydrant and filled

with stones, min size 40mm dia. as specified. The space about the barrel and 150mm above the drip hole shall also be filled.

- .6 Follow City of Lethbridge installation standards.
- .7 A .015 polyethylene sheet shall be placed over the top of the stones to prevent the spaces between the stones filling with soil.
- .8 Allow for restraints to be added as directed by U of L Utilities dept.
- .9 Place 2 ply of polyethylene between pipe and poured concrete.
- .10 Concrete shall be sulfate resistant, 20MPa @ 28 days.
- .11 Thrust blocks required at 45- and 90-degree pipe turns.
- .12 Fire Hydrants in use on campus are Canada Value Century.

40 90 00 PRIMARY CONTROL DEVICES

40 91 00 Primary Control Valves

40 91 13 Electrically Operated Primary Control Valves

40 91 16 Hydraulically Operated Primary Control Valves

40 91 19 Pneumatically Operated Primary Control Valves

40 91 23 Solenoid Primary Control Valves

40 91 26 Specialty Primary Control Valves

40 92 00 Self-Contained Flow Controllers

40 93 00 Linear Actuators and Positioners

40 94 00 Self-Contained Pressure Regulators

40 95 00 Rotary Actuators

40 96 00 Saturable Core Reactors

40 97 00 Variable Frequency Drivers

- .1 Variable Frequency Drives (VFD) are not to be mounted in MCC or on high vibration surfaces that can generate and transfer to VFD. Proper vibration isolation must be always maintained.

VFD shall be mounted at normal working height to allow for maintenance and repair with ladder or movable platform. Integrated drives on pumps shall not be accepted.

- .2 Motors for VFD applications shall be for varied operation over the defined speed range and not for continuous operation at a single or limited number of speeds. Motors shall operate continuously at any single speed within the defined speed range. Motors shall be wound using inverter spike resistant magnet wire rated for 3.1 times the rated line-to-line voltage. Shaft grounding brushes shall be used to divert the induced voltage potential between the rotor and stator. Wiring from the secondary of the VFD to the motor is to be 1000 volt rated cable.
- .3 Shut-down labelling is to be applied on all drives, disconnects and starters indicating the safe shut-down and maintenance procedures for the VFD(s). Log sheets are also to be supplied and installed beside each to record faults on the drive for trouble-shooting the VFD performance.